

Carbide **Probes** *Inc.*

CATALOG #20

- Carbide & Ruby Indicator Tips ■
- Custom-Built Contact Points ■
- CMM Replacement Styli ■

CARBIDE AND RUBY REPLACEMENT CONTACT POINTS & STYLI

Precision made for all popular models



Carbide Probes, Inc.

1328 Research Park Drive Dayton, Ohio 45432

Phone: 937.429.9123 Fax: 937.429.2103 Toll Free: 1.800.347.4980

www.carbideprobes.com

Special carbide ball sizes are available in diameters from .005" and up, and special ruby ball sizes are available in diameters from .3mm and up for all contact points, and styli.

Most ball tipped contact points and styli can be provided with silicon nitride, zirconia, delrin, nylon, or teflon balls upon request.

A collection of various dial test indicators with different styles and dials, set against a green background.

DIAL TEST INDICATORS

page 2-15

A collection of electronic gauges, including a large gear-shaped gauge and several smaller probes, set against an orange background.

ELECTRONIC GAUGES

page 16-20

A collection of A.G.D. (Analog Gauge) indicators with various styles and finishes, set against a blue background.

A.G.D. INDICATORS

page 21-31

A collection of CMM (Coordinate Measuring Machine) replacement styli of various shapes and sizes, set against a red background.

CMM REPLACEMENT STYLI

page 32-76

A close-up view of a surface test probe with a textured handle, set against a dark purple background.

SURFACE TEST

page 77-78

A close-up view of a textured surface, possibly a probe tip or a component, set against a dark grey background.



MISCELLANEOUS

page 79-80

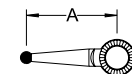
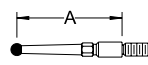
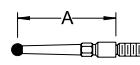
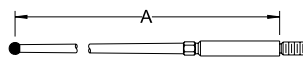
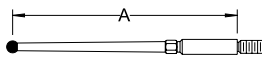



ALINA	A (Length)	Thread Size/Pitch	Model Number	Ball Diameter	T.C. Ball Part Number	Ruby Ball Part Number
	.472"	Ratchet	88	.015" .031" .062" .100"	101-015 101-031 101-062 101-100	101-015R 101-031R 101-062R 101-100R
	.547"	M1.7 x 0.35	M31, M31SM, M32, M33, M34, M34SM	.015" .031" 1mm .062" 2mm .100"	102-015 102-031 102-040 102-062 102-080 102-100	102-015R 102-031R 102-040R 102-062R 102-080R 102-100R
	.512"	M1.7 x 0.35	K22, K24, K26, K28	.015" .031" 1mm .062" 2mm .100"	103-015 103-031 103-040 103-062 103-080 103-100	103-015R 103-031R 103-040R 103-062R 103-080R 103-100R
	1.500"	M1.7 x 0.35	K21, K23, K25, K27	.015" .031" 1mm .062" 2mm .100"	104-015 104-031 104-040 104-062 104-080 104-100	104-015R 104-031R 104-040R 104-062R 104-080R 104-100R
	1.170"	M1.7 x 0.35	M35 SHORT RANGE	.015" .031" 1mm .062" 2mm .100"	105-015 105-031 105-040 105-062 105-080 105-100	105-015R 105-031R 105-040R 105-062R 105-080R 105-100R



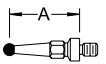

ALINA continued on page 3

ALINA continued from page 2	A (Length)	Thread Size/Pitch	Model Number	Ball Diameter	T.C. Ball Part Number	Ruby Ball Part Number
	.321"	M1.6 x 0.35	524, 526, 531, 532, 622, 628, 633, 634, 724, 726	.015" .031" 1mm .062" 2mm .100"	130-015 130-031 130-040 130-062 130-080 130-100	130-015R 130-031R 130-040R 130-062R 130-080R 130-100R
	1.276"	M1.6 x 0.35	525, 527, 621, 623, 725, 727, 731, 732	.015" .031" 1mm .062" 2mm .100"	131-015 131-031 131-040 131-062 131-080 131-100	131-015R 131-031R 131-040R 131-062R 131-080R 131-100R

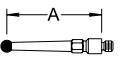
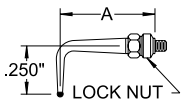
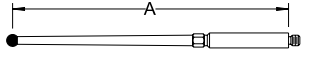
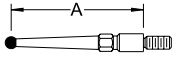
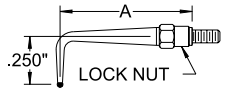
AMES	A (Length)	Thread Size/Pitch	Model Number	Ball Diameter	T.C. Ball Part Number	Ruby Ball Part Number
	.190"	1-72	Trutest #1 - 2	.015" .031" 1mm .062" 2mm .100"	106-015 106-031 106-040 106-062 106-080 106-100	106-015R 106-031R 106-040R 106-062R 106-080R 106-100R

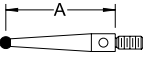
ASH	A (Length)	Thread Size/Pitch	Model Number	Ball Diameter	T.C. Ball Part Number	Ruby Ball Part Number
	.365"	M1.7 x 0.35	N/A	.015" .031" 1mm .062" 2mm .100"	155-015 155-031 155-040 155-062 155-080 155-100	155-015R 155-031R 155-040R 155-062R 155-080R 155-100R

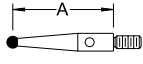
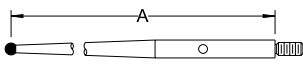
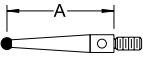
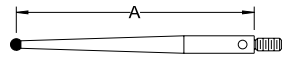

BROWN & SHARPE	A (Length)	Thread Size/Pitch	Model Number	Ball Diameter	T.C. Ball Part Number	Ruby Ball Part Number
	.245"	M1.4 x 0.30	7025, 7027, 7028	.015" .031" 1mm .062" 2mm .100"	107-015 107-031 107-040 107-062 107-080 107-100	107-015R 107-031R 107-040R 107-062R 107-080R 107-100R
	.494"	M1.4 x 0.30	7021, 7022, 7023, 7024, 7029, 7030, 7031, 7032, 7033, 7036, 7037, 7038, 7049, 7050	.015" .031" 1mm .062" 2mm .100"	108-015 108-031 108-040 108-062 108-080 108-100	108-015R 108-031R 108-040R 108-062R 108-080R 108-100R
	.494"	M1.4 x 0.30	7021, 7022, 7023, 7024, 7029, 7030, 7031, 7032, 7033, 7036, 7037, 7038, 7049, 7050	.015" .031" .062"	108-015HP 108-031HP 108-062HP	108-015RHP 108-031RHP 108-062RHP
	1.437"	M1.4 x 0.30	7034, 7035	.015" .031" 1mm .062" 2mm .100"	109-015 109-031 109-040 109-062 109-080 109-100	109-015R 109-031R 109-040R 109-062R 109-080R 109-100R
	.688"	M1.7 x 0.35	7025-4, 7026-4, 7027-4, 7028-4	.015" .031" 1mm .062" 2mm .100"	120-015 120-031 120-040 120-062 120-080 120-100	120-015R 120-031R 120-040R 120-062R 120-080R 120-100R
	.688"	M1.7 x 0.35	7025-4, 7026-4, 7027-4, 7028-4	.015" .031" .062"	120-015HP 120-031HP 120-062HP	120-015RHP 120-031RHP 120-062RHP

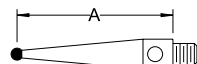
COMPAC	A (Length)	Thread Size/Pitch	Model Number	Ball Diameter	T.C. Ball Part Number	Ruby Ball Part Number
	.573"	M1.6 x 0.35	212A, 214A, 214GA, 215A, 215GA, 224A, 224GA, 225A, 225GA, 234A, 234GA, 235A, 235GA, 245A, 245GA	.015" .031" 1mm .062" 2mm .100"	135-015 135-031 135-040 135-062 135-080 135-100	135-015R 135-031R 135-040R 135-062R 135-080R 105-100R
	1.293"	M1.6 x 0.35	213LA, 213GLA, 223LA, 223GLA, 233LA, 233GLA	.015" .031" 1mm .062" 2mm .100"	136-015 136-031 136-040 136-062 136-080 136-100	136-015R 136-031R 136-040R 136-062R 136-080R 136-100R
	.528"	M1.6 x 0.35	244A, 244GA	.015" .031" 1mm .062" 2mm .100"	137-015 137-031 137-040 137-062 137-080 137-100	137-015R 137-031R 137-040R 137-062R 137-080R 137-100R
	1.652"	M1.6 x 0.35	244LA, 244GLA	.015" .031" 1mm .062" 2mm .100"	145-015 145-031 145-040 145-062 145-080 145-100	145-015R 145-031R 145-040R 145-062R 145-080R 145-100R
	.561"	M1.6 x 0.35	213, 213G, 215, 215G, 216G, 223, 223G, 225, 225G, 233, 233G, 235, 235G, 242, 242G, 245, 245G	.015" .031" 1mm .062" 2mm .100"	162-015 162-031 162-040 162-062 162-080 162-100	162-015R 162-031R 162-040R 162-062R 162-080R 162-100R
	1.269"	M1.6 x 0.35	212L, 212GL, 215GL, 222L, 222GL, 232L, 232GL	.015" .031" 1mm .062" 2mm .100"	163-015 163-031 163-040 163-062 163-080 163-100	163-015R 163-031R 163-040R 163-062R 163-080R 163-100R
	1.624"	M1.6 x 0.35	243L, 243GL	.015" .031" 1mm .062" 2mm .100"	164-015 164-031 164-040 164-062 164-080 164-100	164-015R 164-031R 164-040R 164-062R 164-080R 164-100R

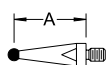
DATCON-HAMILTON	A (Length)	Thread Size/Pitch	Model Number	Ball Diameter	T.C. Ball Part Number	Ruby Ball Part Number
	.812"	4-48	T14, T15, T101	.015" .031" 1mm .062" 2mm .100"	132-015 132-031 132-040 132-062 132-080 132-100	132-015R 132-031R 132-040R 132-062R 132-080R 132-100R

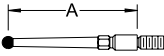

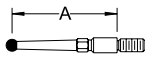
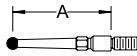
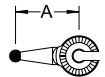
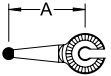
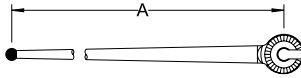
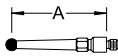
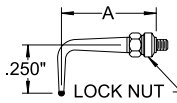

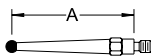

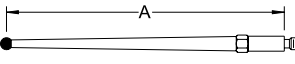
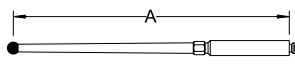

EMS	A (Length)	Thread Size/Pitch	Model Number	Ball Diameter	T.C. Ball Part Number	Ruby Ball Part Number
	.375"	M1.7 x 0.35	N/A	.015" .031" 1mm .062" 2mm .100"	156-015 156-031 156-040 156-062 156-080 156-100	156-015R 156-031R 156-040R 156-062R 156-080R 156-100R

ENCO	A (Length)	Thread Size/Pitch	Model Number	Ball Diameter	T.C. Ball Part Number	Ruby Ball Part Number
	.245"	M1.4 x 0.30	609-00, 609-01, 609-05, 609-06, 609-07	.015" .031" 1mm .062" 2mm .100"	107-015 107-031 107-040 107-062 107-080 107-100	107-015R 107-031R 107-040R 107-062R 107-080R 107-100R
	.660"	M1.6 x 0.35	699-10	.015" .031" 1mm .062" 2mm .100"	146-015 146-031 146-040 146-062 146-080 146-100	146-015R 146-031R 146-040R 146-062R 146-080R 146-100R

FEDERAL	A (Length)	Thread Size/Pitch	Model Number	Ball Diameter	T.C. Ball Part Number	Ruby Ball Part Number
	.547"	M1.7 x 0.35	L2, L6, L10, L12	.015" .031" 1mm .062" 2mm .100"	102-015 102-031 102-040 102-062 102-080 102-100	102-015R 102-031R 102-040R 102-062R 102-080R 102-100R
	.512"	M1.7 x 0.35	L1, L5, L9, L11	.015" .031" 1mm .062" 2mm .100"	103-015 103-031 103-040 103-062 103-080 103-100	103-015R 103-031R 103-040R 103-062R 103-080R 103-100R
	.331"	Ratchet	T2, T3, T6, T7, LT1/2, LT2, LT6, LT13	.015" .031" .062" .100"	110-015 110-031 110-062 110-100	110-015R 110-031R 110-062R 110-100R
	.398"	Ratchet	T1, T5, T9, LT1, LT5, LT9, LT10	.015" .031" .062" .100"	111-015 111-031 111-062 111-100	111-015R 111-031R 111-062R 111-100R
	1.660"	Ratchet	T11, LT11, LT12	.015" .031" .062" .100"	112-015 112-031 112-062 112-100	112-015R 112-031R 112-062R 112-100R
	.494"	M1.4 x 0.30	LT102, LT104, LT109, LT113, LT123, LT150, T101, T102, T104, T105, T106, T108, T109, T123	.015" .031" 1mm .062" 2mm .100"	108-015 108-031 108-040 108-062 108-080 108-100	108-015R 108-031R 108-040R 108-062R 108-080R 108-100R
	.494"	M1.4 x 0.30	LT102, LT104, LT109, LT113, LT123, LT150, T101, T102, T104, T105, T106, T108, T109, T123	.015" .031" .062"	108-015HP 108-031HP 108-062HP	108-015RHP 108-031RHP 108-062RHP
	.366"	M1.6 x 0.35	T-82, LT-82	.015" .031" 1mm .062" 2mm .100"	150-015 150-031 150-040 150-062 150-080 150-100	150-015R 150-031R 150-040R 150-062R 150-080R 150-100R
	.636"	M1.6 x 0.35	T-83, LT-83, T-85, LT-85	.015" .031" 1mm .062" 2mm .100"	151-015 151-031 151-040 151-062 151-080 151-100	151-015R 151-031R 151-040R 151-062R 151-080R 151-100R

FEDERAL continued on page 6

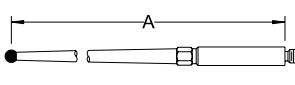
FEDERAL <small>continued from page 5</small>	A (Length)	Thread Size/Pitch	Model Number	Ball Diameter	T.C. Ball Part Number	Ruby Ball Part Number
	1.447"	M1.6 x 0.35	T-84, LT-84, T-86, LT-86	.015" .031" 1mm .062" 2mm .100"	152-015 152-031 152-040 152-062 152-080 152-100	152-015R 152-031R 152-040R 152-062R 152-080R 152-100R
	1.437"	M1.4 x 0.30	T-103, LT-103, T-111, LT-111	.015" .031" 1mm .062" 2mm .100"	109-015 109-031 109-040 109-062 109-080 109-100	109-015R 109-031R 109-040R 109-062R 109-080R 109-100R

FWLER	A (Length)	Thread Size/Pitch	Model Number	Ball Diameter	T.C. Ball Part Number	Ruby Ball Part Number
(VERDICT) 	.306"	Ratchet	52-555-000, 52-555-005, 52-555-666 TYPE C	.015" .031" .062" .100"	113-015 113-031 113-062 113-100	113-015R 113-031R 113-062R 113-100R
(VERDICT) 	.375"	Ratchet	SP Super Test	.015" .031" .062" .100"	114-015 114-031 114-062 114-100	114-015R 114-031R 114-062R 114-100R
(VERDICT) 	.250"	M1.7 x 0.35	52-560-010, 52-560-015, TA4, T5, T7, T500	.015" .031" 1mm .062" 2mm .100"	115-015 115-031 115-040 115-062 115-080 115-100	115-015R 115-031R 115-040R 115-062R 115-080R 115-100R
(VERDICT) 	.344"	M1.7 x 0.35	T1, T2, T4	.015" .031" 1mm .062" 2mm .100"	116-015 116-031 116-040 116-062 116-080 116-100	116-015R 116-031R 116-040R 116-062R 116-080R 116-100R
(VERDICT) 	.605"	M1.7 x 0.35	T8, 52-560-005	.015" .031" 1mm .062" 2mm .100"	117-015 117-031 117-040 117-062 117-080 117-100	117-015R 117-031R 117-040R 117-062R 117-080R 117-100R
(VERDICT) 	.674"	M1.7 x 0.35	T15	.015" .031" 1mm .062" 2mm .100"	118-015 118-031 118-040 118-062 118-080 118-100	118-015R 118-031R 118-040R 118-062R 118-080R 118-100R
(VERDICT) 	.860"	M1.7 x 0.35	T6	.015" .031" 1mm .062" 2mm .100"	139-015 139-031 139-040 139-062 139-080 139-100	139-015R 139-031R 139-040R 139-062R 139-080R 139-100R
	2.890"	M1.7 x 0.35	52-555-022, 52-555-023	.015" .031" 1mm .062" 2mm .100"	158-015 158-031 158-040 158-062 158-080 158-100	158-015R 158-031R 158-040R 158-062R 158-080R 158-100R
(ULTRA-TAST) 	.516"	M1.6 x 0.35	52-568-005, 52-568-006, 52-568-010, 52-568-011, 52-568-015, 52-568-016, 52-568-020	.015" .031" 1mm .062" 2mm .100"	143-015 143-031 143-040 143-062 143-080 143-100	143-015R 143-031R 143-040R 143-062R 143-080R 143-100R
(ULTRA-TAST) 	.545"	M1.6 x 0.35	52-568-021	.015" .031" 1mm .062" 2mm .100"	159-015 159-031 159-040 159-062 159-080 159-100	159-015R 159-031R 159-040R 159-062R 159-080R 159-100R

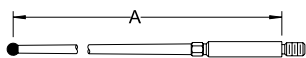
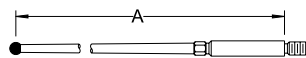
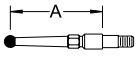
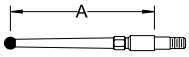
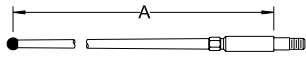
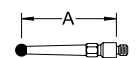
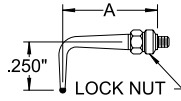
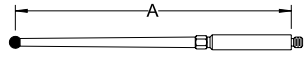
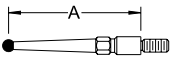
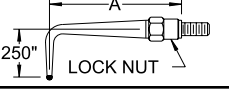
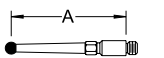

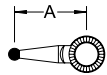
FOWLER continued from page 6	A (Length)	Thread Size/Pitch	Model Number	Ball Diameter	T.C. Ball Part Number	Ruby Ball Part Number
 (ULTRA-TAST)	1.378"	M1.6 x 0.35	52-568-022	.015" .031" 1mm .062" 2mm .100"	160-015 160-031 160-040 160-062 160-080 160-100	160-015R 160-031R 160-040R 160-062R 160-080R 160-100R
 (ULTRA-TAST)	1.457"	M1.6 x 0.35	52-568-023	.015" .031" 1mm .062" 2mm .100"	161-015 161-031 161-040 161-062 161-080 161-100	161-015R 161-031R 161-040R 161-062R 161-080R 161-100R
 (GIROD-TAST)	.480	M1.6 x 0.35	52-562-252*, 52-562-253, 52-562-272, 52-562-273, 52-562-452*, 52-562-453, 52-562-473, 52-563-252, 52-563-253, 52-563-272, 52-563-273, 52-563-452, 52-563-453, 52-563-473 FOR OLD STYLE INDICATORS WITH M1.6 THREADS *WITHOUT REVOLUTION COUNTER	.015" .031" 1mm .062" 2mm .100"	138-015 138-031 138-040 138-062 138-080 138-100	138-015R 138-031R 138-040R 138-062R 138-080R 138-100R
 (GIROD-TAST)	.750"	M1.6 x 0.35	52-562-252, 52-562-452, FOR INDICATORS WITH REVOLUTION COUNTER	.015" .031" 1mm .062" 2mm .100"	147-015 147-031 147-040 147-062 147-080 147-100	147-015R 147-031R 147-040R 147-062R 147-080R 147-100R
 (GIROD-TAST)	1.415"	M1.6 x 0.35	52-562-474, 52-563-474, FOR OLD STYLE INDICATORS WITH M1.6 THREADS	.015" .031" 1mm .062" 2mm .100"	148-015 148-031 148-040 148-062 148-080 148-100	148-015R 148-031R 148-040R 148-062R 148-080R 148-100R
 (GIROD-TAST)	.494"	M1.4 x 0.30	52-562-253, 52-562-272, 52-562-273, 52-562-453, 52-562-473, 52-563-252, 52-563-253, 52-563-272, 52-563-273, 52-563-452, 52-563-453, 52-563-473, 54-562-777 FOR NEW STYLE INDICATORS WITH M1.4 THREADS	.015" .031" 1mm .062" 2mm .100"	108-015 108-031 108-040 108-062 108-080 108-100	108-015R 108-031R 108-040R 108-062R 108-080R 108-100R
 (GIROD-TAST)	.494"	M1.4 x 0.30	52-562-253, 52-562-272, 52-562-273, 52-562-453, 52-562-473, 52-563-252, 52-563-253, 52-563-272, 52-563-273, 52-563-452, 52-563-453, 52-563-473, 54-562-777 FOR NEW STYLE INDICATORS WITH M1.4 THREADS	.015" .031" .062"	108-015 108-031 108-062	108-015R 108-031R 108-062R
 (GIROD-TAST)	1.437"	M1.4 x 0.30	52-562-474, 52-563-474, 54-562-888 FOR NEW STYLE INDICATORS WITH M1.4 THREADS	.015" .031" 1mm .062" 2mm .100"	109-015 109-031 109-040 109-062 109-080 109-100	109-015R 109-031R 109-040R 109-062R 109-080R 109-100R
 (X-TEST)	.688"	M1.7 x 0.35	52-562-001, 52-562-002, 52-562-003, 52-562-004, 52-562-005, 52-562-006	.015" .031" 1mm .062" 2mm .100"	120-015 120-031 120-040 120-062 120-080 120-100	120-015R 120-031R 120-040R 120-062R 120-080R 120-100R
 (X-TEST)	.688"	M1.7 x 0.35	52-562-001, 52-562-002, 52-562-003, 52-562-004, 52-562-005, 52-562-006	.015" .031" .062"	120-015HP 120-031HP 120-062HP	120-015RHP 120-031RHP 120-062RHP
 (X-TEST)	.537"	M2 x 0.4	52-562-774, 52-562-775, 52-562-776, 52-562-778, 52-562-780	.015" .031" 1mm .062" 2mm .100"	185-015 185-031 185-040 185-062 185-080 185-100	185-015R 185-031R 185-040R 185-062R 185-080R 185-100R

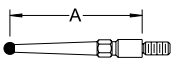
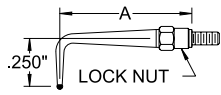
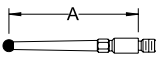
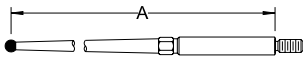
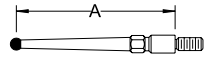
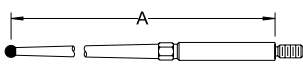
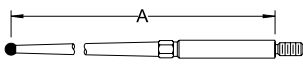

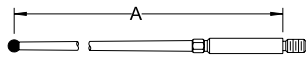
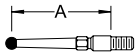
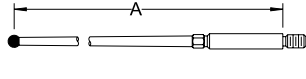
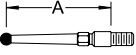
GEM	A (Length)	Ratchet	Model Number	Ball Diameter	T.C. Ball Part Number	Ruby Ball Part Number
	.375"	Ratchet	222, 225, 250, 300, 325, 333, 334, 335	.015" .031" .062" .100"	119-015 119-031 119-062 119-100	119-015R 119-031R 119-062R 119-100R

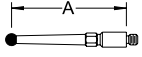
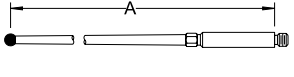
INTERAPID	A (Length)	Thread Size/Pitch	Model Number	Ball Diameter	T.C. Ball Part Number	Ruby Ball Part Number
	.688"	M1.7 x 0.35	74.111366, 74.111367, 74.111370, 74.111371, 74.111372, 74.111373, 74.111374, 74.111375, 74.111376, 74.111377, 74.111378, 74.111379, 74.111957, 310B-1, 310B-1V, 310B-2, 310B-2V, 310B-20, 310B-20V, 311, 311B-2, 312-1, 312-2, 312-IV, 312-2V, 312B-1, 312B-1V, 312B-2, 312B-2V, 312B-3, 312B-3V, 312B-4, 312B-20, 312B-20V	.015" .031" 1mm .062" 2mm .100"	120-015 120-031 120-040 120-062 120-080 120-100	120-015R 120-031R 120-040R 120-062R 120-080R 120-100R
	.688"	M1.7 x 0.35	74.111366, 74.111367, 74.111370, 74.111371, 74.111372, 74.111373, 74.111374, 74.111375, 74.111376, 74.111377, 74.111378, 74.111379, 74.111957, 310B-1, 310B-1V, 310B-2, 310B-2V, 310B-20, 310B-20V, 311, 311B-2, 312-1, 312-2, 312-IV, 312-2V, 312B-1, 312B-1V, 312B-2, 312B-2V, 312B-3, 312B-3V, 312B-4, 312B-20, 312B-20V	.015" .031" .062"	120-015HP 120-031HP 120-062HP	120-015RHP 120-031RHP 120-062RHP
	.676"	M1.7 x 0.35	74.111368, 74.111369, 312-3, 312-4	.015" .031" 1mm .062" 2mm .100"	186-015 186-031 186-040 186-062 186-080 186-100	186-015R 186-031R 186-040R 186-062R 186-080R 186-100R
	1.450"	M1.7 x 0.35	310B-L1, 310B-L2 MAY BE USED AS A DOUBLE LENGTH TIP FOR MODELS LISTED ABOVE (120 SERIES)	.015" .031" 1mm .062" 2mm .100"	121-015 121-031 121-040 121-062 121-080 121-100	121-015R 121-031R 121-040R 121-062R 121-080R 121-100R
	.827"	M1.7 x 0.35	310B-3, 311B-3 STANDARD LENGTH	.015" .031" 1mm .062" 2mm .100"	129-015 129-031 129-040 129-062 129-080 129-100	129-015R 129-031R 129-040R 129-062R 129-080R 129-100R
	1.750"	M1.7 x 0.35	310B-3, 311B-3 DOUBLE LENGTH	.015" .031" 1mm .062" 2mm .100"	149-015 149-031 149-040 149-062 149-080 149-100	149-015R 149-031R 149-040R 149-062R 149-080R 149-100R
	2.750"	M1.7 x 0.35	74.111958, 312B-15, 312B-15V	.015" .031" 1mm .062" 2mm .100"	142-015 142-031 142-040 142-062 142-080 142-100	142-015R 142-031R 142-040R 142-062R 142-080R 142-100R

MAHR	A (Length)	Thread Size/Pitch	Model Number	Ball Diameter	T.C. Ball Part Number	Ruby Ball Part Number
MAHR PUPPISTAST INDICATORS DISCONTINUED BY MAHR - M1.6 THDS						
	1.378"	M1.6 x 0.35	800SLZ	.015" .031" 1mm .062" 2mm .100"	160-015 160-031 160-040 160-062 160-080 160-100	160-015R 160-031R 160-040R 160-062R 160-080R 160-100R
	.516"	M1.6 x 0.35	800S, 800SG, 800SGI, 800SGZ, 800SM, 800SZ, 800SMZ, 800WZ, 801TH	.015" .031" 1mm .062" 2mm .100"	143-015 143-031 143-040 143-062 143-080 143-100	143-015R 143-031R 143-040R 143-062R 143-080R 143-100R
	1.457"	M1.6 x 0.35	800SL	.015" .031" 1mm .062" 2mm .100"	161-015 161-031 161-040 161-062 161-080 161-100	161-015R 161-031R 161-040R 161-062R 161-080R 161-100R
	.545"	M1.6 x 0.35	800W	.015" .031" 1mm .062" 2mm .100"	159-015 159-031 159-040 159-062 159-080 159-100	159-015R 159-031R 159-040R 159-062R 159-080R 159-100R

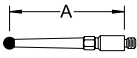
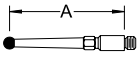
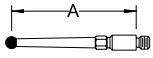
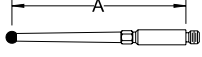
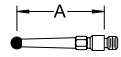
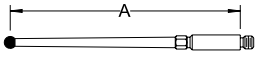
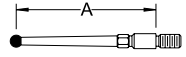
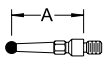

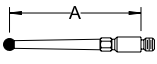
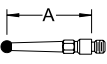
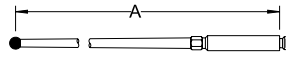
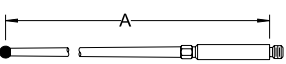
MARTEST INDICATORS - M2 THDS						
	.571"	M2 x 0.4	800S, 801S1, 801S, 800SG, 801SG, 800SA, 800SGA, 800SM, 801SM, 800SGM, 801SGM, 801SGE, 800SR, 801SR, 800SRM, 801SRM, 800H, 801H, 800V, 801V, 800VGM, 801VGM, 800EW	.015" .031" 1mm .062" 2mm .100"	183-015 183-031 183-040 183-062 183-080 183-100	183-015R 183-031R 183-040R 183-062R 183-080R 183-100R
	1.622"	M2 x 0.4	800, 801SL, 800SGL, 801SGL, 800EWL	.015" .031" 1mm .062" 2mm .100"	184-015 184-031 184-040 184-062 184-080 184-100	184-015R 184-031R 184-040R 184-062R 184-080R 184-100R

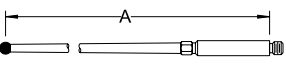

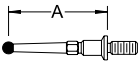
MITUTOYO	A (Length)	Thread Size/Pitch	Model Number	Ball Diameter	T.C. Ball Part Number	Ruby Ball Part Number
	.256"	M1.4 x 0.30	513-302, 513-302G, 513-302GT, 513-304, 513-304GE, 513-304GT, 513-942, 513-944	.015" .031" 1mm	182-015 182-031 182-040	182-015R 182-031R 182-040R
			FOR OLD STYLE INDICATORS WITH EXTENSION	.062" 2mm .100"	182-062 182-080 182-100	182-062R 182-080R 182-100R
	.352"	M1.4 x 0.30	513-102	.015" .031" 1mm .062" 2mm .100"	124-015 124-031 124-040 124-062 124-080 124-100	124-015R 124-031R 124-040R 124-062R 124-080R 124-100R
	.598"	M1.4 x 0.30	FOR OLD STYLE INDICATORS 513-104, 513-104-1	.015" .031" 1mm .062" 2mm .100"	125-015 125-031 125-040 125-062 125-080 125-100	125-015R 125-031R 125-040R 125-062R 125-080R 125-100R
	.598"	M1.7 x 0.35	FOR NEW STYLE INDICATORS 513-104, 513-104-1 513-128, 513-128-1 513-528, 513-528T, 513-504, 513-504T	.015" .031" 1mm .062" 2mm .100"	157-015 157-031 157-040 157-062 157-080 157-100	157-015R 157-031R 157-040R 157-062R 157-080R 157-100R
	.649"	M1.7 x 0.35	513-206, 513-242, 513-252, 513-262, 513-282G, 513-282GT, 513-402, 513-402T, 513-406, 513-406T, 513-442, 513-442T, 513-442-01, 513-442T-01, 513-442-06, 513-442T-06, 513-452, 513-452T, 513-462, 513-472, 513-906, 513-907, 513-952, 513-982	.015" .031" 1mm .062" 2mm .100"	126-015 126-031 126-040 126-062 126-080 126-100	126-015R 126-031R 126-040R 126-062R 126-080R 126-100R
			FOR NEW STYLE INDICATORS 513-202, 513-202N, 513-282, 513-902, 513-902N			
	.906"	M1.7 x 0.35	513-518, 513-518T	.015" .031" 1mm .062" 2mm .100"	128-015 128-031 128-040 128-062 128-080 128-100	128-015R 128-031R 128-040R 128-062R 128-080R 128-100R
			FOR NEW STYLE INDICATORS 513-118, 513-118-1			
	.455"	M1.7 x 0.35	513-203, 513-203N, 513-223, 513-243, 513-403, 513-403T, 513-443, 513-443-06, 513-443T, 513-443T-06, 513-453, 513-453T, 513-463, 513-903, 513-953	.015" .031" 1mm .062" 2mm .100"	140-015 140-031 140-040 140-062 140-080 140-100	140-015R 140-031R 140-040R 140-062R 140-080R 140-100R
			FOR NEW STYLE INDICATORS 513-253			
	1.198"	M1.7 x 0.35	513-412, 513-412T, 513-446, 513-446T, 513-446-06, 513- 446T-06	.015" .031" 1mm .062" 2mm .100"	141-015 141-031 141-040 141-062 141-080 141-100	141-015R 141-031R 141-040R 141-062R 141-080R 141-100R
			FOR NEW STYLE INDICATORS 513-212, 513-212N, 513-922, 513-922N			
	.738"	M1.7 x 0.35	513-424E, 513-426E, 513-466E	.015" .031" 1mm .062" 2mm .100"	187-015 187-031 187-040 187-062 187-080 187-100	187-015R 187-031R 187-040R 187-062R 187-080R 187-100R
	.369"	M1.7 x 0.35	513-401E	.015" .031" 1mm .062" 2mm .100"	188-015 188-031 188-040 188-062 188-080 188-100	188-015R 188-031R 188-040R 188-062R 188-080R 188-100R

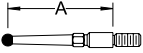
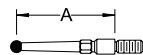
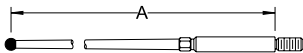
MITUTOYO continued from page 10	A (Length)	Thread Size/Pitch	Model Number	Ball Diameter	T.C. Ball Part Number	Ruby Ball Part Number
	.685"	M1.7 x 0.35	513-117, 513-117H, 513-204FE, 513-204N, 513-284GE, 513-284GT, 513-404E, 513-404T, 513-444E, 513-444T, 513-454E, 513-454T, 513-464E, 513-474E, 513-517E, 513-517T, 513-904, 513-904F, 513-908, 513-954F, 513-984F	.015" .031" 1mm .062" 2mm .100"	166-015 166-031 166-040 166-062 166-080 166-100	166-015R 166-031R 166-040R 166-062R 166-080R 166-100R
	.441"	M1.7 x 0.35	513-103, 513-103H, 513-115, 513-127, 513-127H, 513-205FE, 513-205N, 513-255FA, 513-405E, 513-405T, 513-409, 513-409T, 513-425E, 513-445E, 513-445T, 513-455E, 513-455T, 513-465E, 513-503E, 513-527, 513-527E, 513-905F, 513-955F	.015" .031" 1mm .062" 2mm .100"	167-015 167-031 167-040 167-062 167-080 167-100	167-015R 167-031R 167-040R 167-062R 167-080R 167-100R
	1.335"	M1.7 x 0.35	513-112, 513-112-1, 513-512, 513-512T	.015" .031" 1mm .062" 2mm .100"	168-015 168-031 168-040 168-062 168-080 168-100	168-015R 168-031R 168-040R 168-062R 168-080R 168-100R
	1.614"	M1.7 x 0.35	513-115, 513-115H, 513-415E, 513-415T, 513-515T	.015" .031" 1mm .062" 2mm .100"	169-015 169-031 169-040 169-062 169-080 169-100	169-015R 169-031R 169-040R 169-062R 169-080R 169-100R
	.335"	M1.7 x 0.35	513-101, 513-101H, 513-501E, 513-501T	.015" .031" 1mm .062" 2mm .100"	180-015 180-031 180-040 180-062 180-080 180-100	180-015R 180-031R 180-040R 180-062R 180-080R 180-100R
	1.311"	M1.7 x 0.35	513-414E, 513-414T, 513-924F, 513-514E, 513-514T	.015" .031" 1mm .062" 2mm .100"	181-015 181-031 181-040 181-062 181-080 181-100	181-015R 181-031R 181-040R 181-062R 181-080R 181-100R

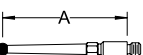
MUELLER	A (Length)	Thread Size/Pitch	Model Number	Ball Diameter	T.C. Ball Part Number	Ruby Ball Part Number
	.515"	M1.7 x 0.35	G301, G301K, G302, G303, G304, G306, G306K, G307, G308, G309	.015" .031" 1mm .062" 2mm .100"	123-015 123-031 123-040 123-062 123-080 123-100	123-015R 123-031R 123-040R 123-062R 123-080R 123-100R

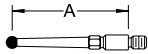

PARVUS-COMPAC	A (Length)	Thread Size/Pitch	Model Number	Ball Diameter	T.C. Ball Part Number	Ruby Ball Part Number
	.547"	M1.7 x 0.35	V3, P3G, V3G, P3GA	.015" .031" 1mm .062" 2mm .100"	102-015 102-031 102-040 102-062 102-080 102-100	102-015R 102-031R 102-040R 102-062R 102-080R 102-100R
	.512"	M1.7 x 0.35	V2, P2G, V2G, P2GA	.015" .031" 1mm .062" 2mm .100"	103-015 103-031 103-040 103-062 103-080 103-100	103-015R 103-031R 103-040R 103-062R 103-080R 103-100R
	1.500"	M1.7 x 0.35	V2GL, P2GLA	.015" .031" 1mm .062" 2mm .100"	104-015 104-031 104-040 104-062 104-080 104-100	104-015R 104-031R 104-040R 104-062R 104-080R 104-100R

PEACOCK	A (Length)	Thread Size/Pitch	Model Number	Ball Diameter	T.C. Ball Part Number	Ruby Ball Part Number
	.649"	M1.7 x 0.35	20-400, 2000, 2050, 2200	.015" .031" 1mm .062" 2mm .100"	126-015 126-031 126-040 126-062 126-080 126-100	126-015R 126-031R 126-040R 126-062R 126-080R 126-100R
	.375"	M1.7 x 0.35	20-406-6, 2010, 2060, 2210	.015" .031" 1mm .062" 2mm .100"	153-015 153-031 153-040 153-062 153-080 153-100	153-015R 153-031R 153-040R 153-062R 153-080R 153-100R

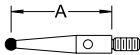
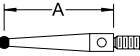
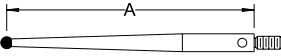
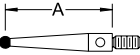
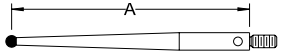
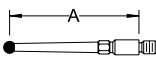
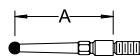
SCHERR-TUMICO	A (Length)	Thread Size/Pitch	Model Number	Ball Diameter	T.C. Ball Part Number	Ruby Ball Part Number
	.306"	Ratchet	F1 F2 F5	.015" .031" .062" .100"	113-015 113-031 113-062 113-100	113-015R 113-031R 113-062R 113-100R
	.250"	M1.7 x 0.35	FX1 FX13 FX15	.015" .031" 1mm .062" 2mm .100"	115-015 115-031 115-040 115-062 115-080 115-100	115-015R 115-031R 115-040R 115-062R 115-080R 115-100R
	.605"	M1.7 x 0.35	FX11	.015" .031" 1mm .062" 2mm .100"	117-015 117-031 117-040 117-062 117-080 117-100	117-015R 117-031R 117-040R 117-062R 117-080R 117-100R

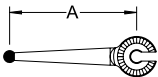
SPI	A (Length)	Thread Size/Pitch	Model Number	Ball Diameter	T.C. Ball Part Number	Ruby Ball Part Number
	.528"	M1.6 x 0.35	20-051-9, 20-053-5	.015" .031" 1mm .062" 2mm .100"	137-015 137-031 137-040 137-062 137-080 137-100	137-015R 137-031R 137-040R 137-062R 137-080R 137-100R
	.573"	M1.6 x 0.35	20-160-8, 20-164-0, 20-052-7, 20-054-3, 20-055-0, 20-140-0, 20-141-8, 20-144-2, 20-145-9, 20-150-9, 20-151-7, 20-154-1, 20-155-8	.015" .031" 1mm .062" 2mm .100"	135-015 135-031 135-040 135-062 135-080 135-100	135-015R 135-031R 135-040R 135-062R 135-080R 135-100R
	1.293"	M1.6 x 0.35	20-142-6, 20-143-4, 20-152-5, 20-153-3, 20-162-4	.015" .031" 1mm .062" 2mm .100"	136-015 136-031 136-040 136-062 136-080 136-100	136-015R 136-031R 136-040R 136-062R 136-080R 136-100R
	.561"	M1.6 x 0.35	21-140-9, 21-145-8	.015" .031" 1mm .062" 2mm .100"	162-015 162-031 162-040 162-062 162-080 162-100	162-015R 162-031R 162-040R 162-062R 162-080R 162-100R
	1.269"	M1.6 x 0.35	21-153-2	.015" .031" 1mm .062" 2mm .100"	163-015 163-031 163-040 163-062 163-080 163-100	163-015R 163-031R 163-040R 163-062R 163-080R 163-100R
	.674"	M1.7 x 0.35	24-400-4, 24-402-0	.015" .031" 1mm .062" 2mm .100"	118-015 118-031 118-040 118-062 118-080 118-100	118-015R 118-031R 118-040R 118-062R 118-080R 118-100R
	.512"	M1.7 x 0.35	24-401-2	.015" .031" 1mm .062" 2mm .100"	103-015 103-031 103-040 103-062 103-080 103-100	103-015R 103-031R 103-040R 103-062R 103-080R 103-100R

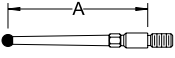
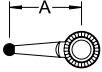
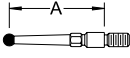
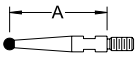
STANDARD GAUGE	A (Length)	Ratchet	Model Number	Ball Diameter	T.C. Ball Part Number	Ruby Ball Part Number
	.331"	Ratchet	24N, 25N, 27N, 28N, 34N	.015" .031" .062" .100"	110-015 110-031 110-062 110-100	110-015R 110-031R 110-062R 110-100R
	.662"	Ratchet	21N, 22N, 25NL, 26N, 32N	.015" .031" .062" .100"	127-015 127-031 127-062 127-100	127-015R 127-031R 127-062R 127-100R

STARRET-LASTWORD	A (Length)	Thread Size/Pitch	Model Number	Ball Diameter	T.C. Ball Part Number	Ruby Ball Part Number
	.728"	1-64	708, 709	.015" .031" 1mm .062" 2mm .100"	165-015 165-031 165-040 165-062 165-080 165-100	165-015R 165-031R 165-040R 165-062R 165-080R 165-100R
	.375"	Ratchet	711 SERIES LASTWORD	.015" .031" .062" .100"	122-015 122-031 122-062 122-100	122-015R 122-031R 122-062R 122-100R
	.495"	1-64	711-T	.015" .031" 1mm .062" 2mm .100"	134-015 134-031 134-040 134-062 134-080 134-100	134-015R 134-031R 134-040R 134-062R 134-080R 134-100R
	.515"	1-64	811 Short	.015" .031" 1mm .062" 2mm .100"	144-015 144-031 144-040 144-062 144-080 144-100	144-015R 144-031R 144-040R 144-062R 144-080R 144-100R
	1.196"	1-64	811 Long	.015" .031" 1mm .062" 2mm .100"	154-015 154-031 154-040 154-062 154-080 154-100	154-015R 154-031R 154-040R 154-062R 154-080R 154-100R

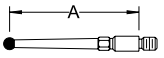
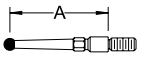
TECLOCK	A (Length)	Ratchet	Model Number	Ball Diameter	T.C. Ball Part Number	Ruby Ball Part Number
	.674"	M1.7 x 0.35	LTI-352	.015" .031" 1mm .062" 2mm .100"	118-015 118-031 118-040 118-062 118-080 118-100	118-015R 118-031R 118-040R 118-062R 118-080R 118-100R
	.512"	M1.7 x 0.35	LTI-355	.015" .031" 1mm .062" 2mm .100"	103-015 103-031 103-040 103-062 103-080 103-100	103-015R 103-031R 103-040R 103-062R 103-080R 103-100R

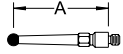
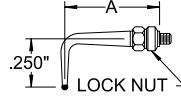
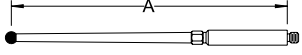
TESA	A (Length)	Thread Size/Pitch	Model Number	Ball Diameter	T.C. Ball Part Number	Ruby Ball Part Number
	.245"	M1.4 x 0.3	20-202	.015" .031" 1mm .062" 2mm .100"	107-015 107-031 107-040 107-062 107-080 107-100	107-015R 107-031R 107-040R 107-062R 107-080R 107-100R
	.494"	M1.4 x 0.3	18.10005, 18.10006, 18.10009, 18.10010, 18.10011, 18.10013, 18.10204, 18.10304, 18.20006, 18.20007, 18.20010, 18.20011, 18.20012, 18.20013, 18.20014, 18.20015, 18.20204, 18.20304, 01830001	.015" .031" 1mm .062" 2mm .100"	108-015 108-031 108-040 108-062 108-080 108-100	108-015R 108-031R 108-040R 108-062R 108-080R 108-100R
 (Hook Point)	.494"	M1.4 x 0.3	18.10005, 18.10006, 18.10009, 18.10010, 18.10011, 18.10013, 18.10204, 18.10304, 18.20006, 18.20007, 18.20010, 18.20011, 18.20012, 18.20013, 18.20014, 18.20015, 18.20204, 18.20304, 01830001	.015" .031" .062"	108-015HP 108-031HP 108-062HP	108-015RHP 108-031RHP 108-062RHP
	1.437"	M1.4 x 0.3	18.10007, 18.10008, 18.10012, 18.10205, 18.20008, 18.20009, 18.20016, 18.20205, 01830002	.015" .031" 1mm .062" 2mm .100"	109-015 109-031 109-040 109-062 109-080 109-100	109-015R 109-031R 109-040R 109-062R 109-080R 109-100R

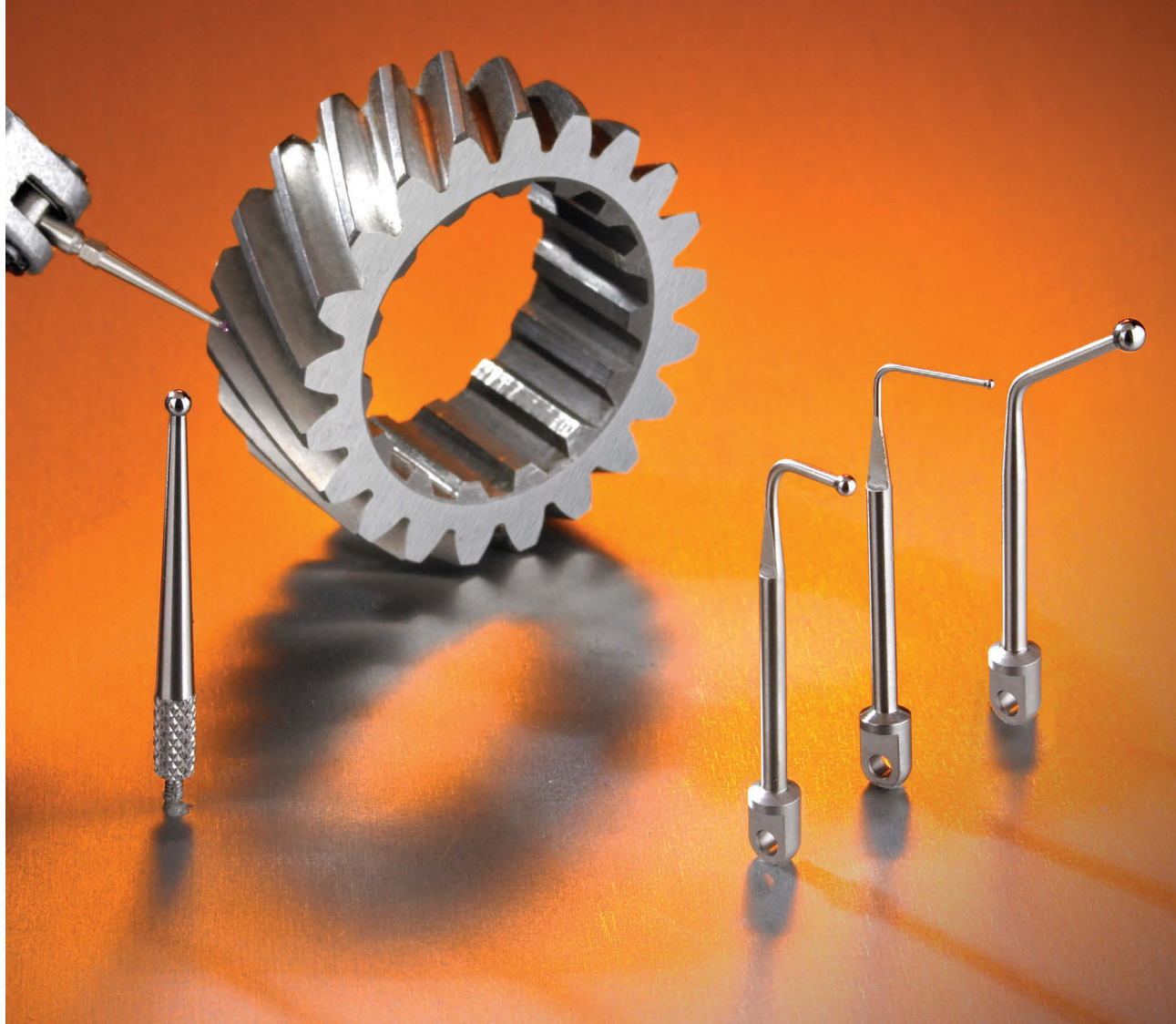

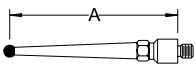

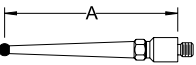
AIRTRONICS	A (Length)	Thread Size/Pitch	Model Number	Ball Diameter	T.C. Ball Part Number	Ruby Ball Part Number
	.875"	1-72	Microtol #1 16522	.015"	201-015	201-015R
				.031"	201-031	201-031R
				.062"	201-062	201-062R
				.100"	201-100	201-100R

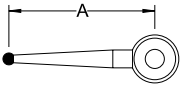
ALINA	A (Length)	Thread Size/Pitch	Model Number	Ball Diameter	T.C. Ball Part Number	Ruby Ball Part Number
	.900"	1-72	1950M	.015"	210-015	210-015R
				.031"	210-031	210-031R
				1mm	210-040	210-040R
				.062"	210-062	210-062R
				2mm	210-080	210-080R
				.100"	210-100	210-100R

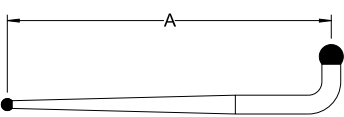
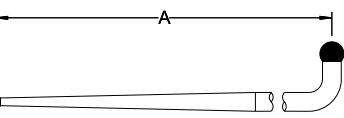
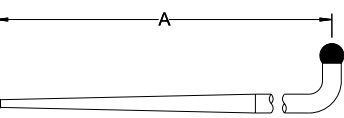
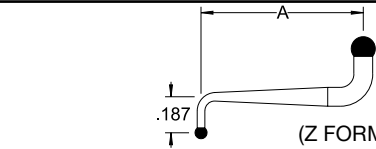
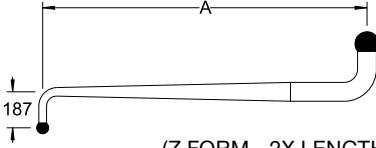
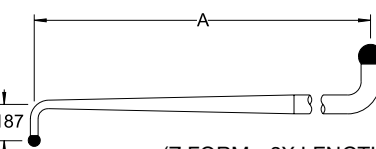
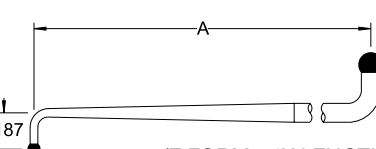
BENDIX-SHEFFIELD	A (Length)	Thread Size/Pitch	Model Number	Ball Diameter	T.C. Ball Part Number
	.760"	N/A	Feather Touch	.015" .031" .062" .100"	214-015 214-031 214-062 214-100

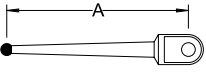
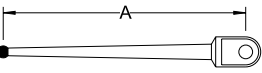
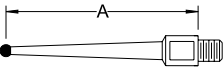
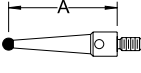
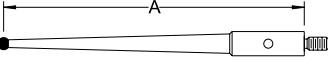
BENDIX-SHEFFIELD/PRECISION DEVICES INC INDI-AC	A (Length)	Thread Size/Pitch	Model Number	Ball Diameter	T.C. Ball Part Number	Ruby Ball Part Number
	.844"	.125" Ball	T210 T220 T225 T425	.015" .031" 1mm .062" 2mm .100"	203-015 203-031 203-040 203-062 203-080 203-100	203-015R 203-031R 203-040R 203-062R 203-080R 203-100R
 (2X LENGTH)	1.688"	.125" Ball	T220 T225 T425	.015" .031" .062" .100"	204-015 204-031 204-062 204-100	
	2.058"	.125" Ball	T210	.015" .031" .062" .100"	229-015 229-031 229-062 229-100	
 (3X LENGTH)	2.532"	.125" Ball	T220 T225 T425	.015" .031" .062" .100"	205-015 205-031 205-062 205-100	
	3.273"	.125" Ball	T210	.015" .031" .062" .100"	230-015 230-031 230-062 230-100	
 (4X LENGTH)	3.376"	.125" Ball	T220 T225 T425	.015" .031" .062" .100"	218-015 218-031 218-062 218-100	
	4.488"	.125" Ball	T210	.015" .031" .062" .100"	231-015 231-031 231-062 231-100	
 (Z FORM)	.844"	.125" Ball	T210 T220 T225 T425	.015" .031" 1mm .062" 2mm .100"	219-015 219-031 219-040 219-062 219-080 219-100	219-015R 219-031R 219-040R 219-062R 219-080R 219-100R
 (Z FORM - 2X LENGTH)	1.688"	.125" Ball	T220 T225 T425	.015" .031" .062" .100"	220-015 220-031 220-062 220-100	
	2.058"	.125" Ball	T210	.015" .031" .062" .100"	232-015 232-031 232-062 232-100	
 (Z FORM - 3X LENGTH)	2.532"	.125" Ball	T220 T225 T425	.015" .031" .062" .100"	221-015 221-031 221-062 221-100	
	3.273"	.125" Ball	T210	.015" .031" .062" .100"	233-015 233-031 233-062 233-100	
 (Z FORM - 4X LENGTH)	3.376"	.125" Ball	T220 T225 T425	.015" .031" .062" .100"	222-015 222-031 222-062 222-100	
	4.488"	.125" Ball	T210	.015" .031" .062" .100"	234-015 234-031 234-062 234-100	

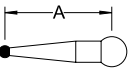
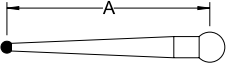
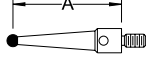
BROWN & SHARPE	A (Length)	Thread Size/Pitch	Model Number	Ball Diameter	T.C. Ball Part Number	Ruby Ball Part Number
	.945"	N/A	599-980, 981	.015" .031" 1mm .062" 2mm .100"	202-015 202-031 202-040 202-062 202-080 202-100	202-015R 202-031R 202-040R 202-062R 202-080R 202-100R
	1.260"	N/A	599-988 (TESA GT31)	.015" .031" 1mm .062" 2mm .100"	223-015 223-031 223-040 223-062 223-080 223-100	223-015R 223-031R 223-040R 223-062R 223-080R 223-100R
	1.000"	4-40	599-1002	.015" .031" .062" .100"	224-015 224-031 224-062 224-100	
	.563"	M1.7 x 0.35	599-999-1	.015" .031" .062" .100"	227-015 227-031 227-062 227-100	
	1.563"	M1.7 x 0.35	599-999-2	.015" .031" .062" .100"	228-015 228-031 228-062 228-100	

BRUNSWICK	A (Length)	Thread Size/Pitch	Model Number	Ball Diameter	Part Number
	.555"	.156" Ball	Finger Probe 221	.015" .031" .062" .100"	215-015 215-031 215-062 215-100
	1.055"	.156" Ball	Finger Probe 221	.015" .031" .062" .100"	216-015 216-031 216-062 216-100
	.563"	M1.7 x 0.35	Finger Probe 24-00-1	.015" .031" .062" .100"	227-015 227-031 227-062 227-100
	1.563"	M1.7 x 0.35	Finger Probe 24-00-2	.015" .031" .062" .100"	228-015 228-031 228-062 228-100

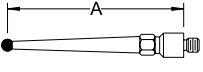
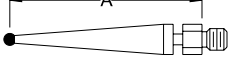
DO-ALL	A (Length)	Thread Size/Pitch	Model Number	Ball Diameter	Part Number
	.915"	1-72	Trans-Check TC-510-3	.015" .031" .062" .100"	206-015 206-031 206-062 206-100
	1.000"	4-40	T	.015" .031" .062" .100"	235-015 235-031 235-062 235-100

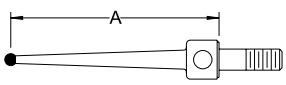
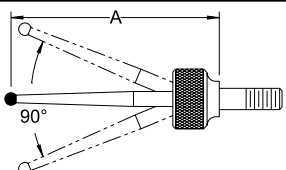
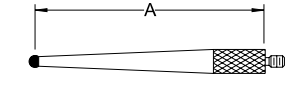
FEDERAL	A (Length)	Thread Size/Pitch	Model Number	Ball Diameter	T.C. Ball Part Number	Ruby Ball Part Number	Delrin Ball Part Number
	1.085"	4-48	EHE-1048, EHE-1050, EHE-1052, EHE-1056, EHE-1115, EHE-1165, EHE-2048, EHE-2050, EHE-2052, EHE-2056 LEVER GAUGE HEAD	.015" .031" 1mm .062" 2mm .100" .125"	207-015 207-031 207-040 207-062 207-080 207-100 207-125	207-015R 207-031R 207-040R 207-062R 207-080R 207-100R 207-125R	N/A N/A N/A 207-062D 207-080D N/A 207-125D
	1.085"	4-48	EHE-1048, EHE-1050, EHE-1052, EHE-1056, EHE-1115, EHE-1165, EHE-2048, EHE-2050, EHE-2052, EHE-2056 LEVER GAUGE HEAD	.015" .031" .062" 2mm .100" .125"	225-015 225-031 225-062 225-080 225-100 225-125	225-015R 225-031R 225-062R 225-080R 225-100R 225-125R	N/A N/A 225-062D 225-080D N/A 225-125D
	1.199"	0-80	EHE-2168, EHE-2172 MINIATURE STYLE LEVER GAUGE HEAD	.015" .031" 1mm .062" 2mm .100" .125"	237-015 237-031 237-040 237-062 237-080 237-100 237-125	237-015R 237-031R 237-040R 237-062R 237-080R 237-100R 237-125R	N/A N/A N/A 237-062D 237-080D N/A 237-125D

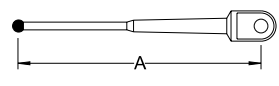
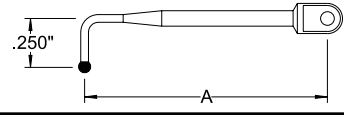
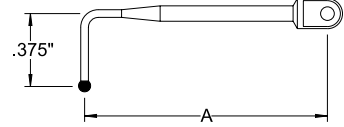
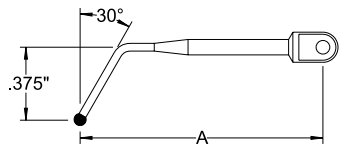
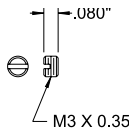
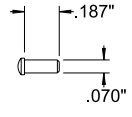
M&M PRECISION	A (Length)	Ball Diameter	Part Number
	1.260"	.015" .031" .046" .062" .100" .250"	241-015 241-031 241-046 241-062 241-100 241-250
	1.260"	.015" .031" .046" .062" .100"	242-015 242-031 242-046 242-062 242-100
	1.260"	.015" .031" .046" .062" .100" .250"	243-015 243-031 243-046 243-062 243-100 243-250
	1.260"	.015" .031" .046" .062" .100" .250"	244-015 244-031 244-046 244-062 244-100 244-250
REPLACEMENT SCREW 			245
REPLACEMENT PIN 			246

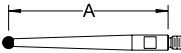
MAHR	A (Length)	Thread Size/Pitch	Model Number	Ball Diameter	Part Number
	.827"	M1.6 x 0.35	1318	.015" .031" .062" .100"	226-015 226-031 226-062 226-100

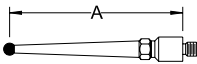
MINNETECH	A (Length)	Thread Size/Pitch	Model Number	Ball Diameter	Part Number
	.900"	1-72	MS-103	.015" .031" .062" .100"	210-015 210-031 210-062 210-100

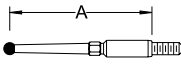
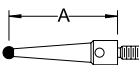
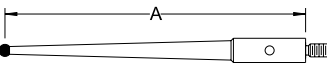
MITUTOYO	A (Length)	Thread Size/Pitch	Model Number	Ball Diameter	Part Number
	.352"	M1.4 x 0.3	519-106 519-321 519-322	.015" .031" .062" .100"	124-015 124-031 124-062 124-100
	.739"	M1.6 x 0.2	574-004 574-005 574-006 574-007	.015" .031" .062" .100"	236-015 236-031 236-062 236-100
	.563"	M1.7 x 0.35	519-899 "Short" STANDARD LENGTH TIP	.015" .031" .062" .100"	227-015 227-031 227-062 227-100
	1.563"	M1.7 x 0.35	519-899 "Long" EXTRA LENGTH TIP	.015" .031" .062" .100"	228-015 228-031 228-062 228-100

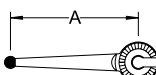
PRATT & WHITNEY	A (Length)	Ratchet	Model Number	Ball Diameter	Part Number
	.662"	Ratchet	Trans-O-Limit D-E	.015" .031" .062" .100"	212-015 212-031 212-062 212-100

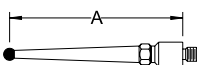
SOLARTRON	A (Length)	Thread Size/Pitch	Model Number	Ball Diameter	T.C. Ball Part Number	Ruby Ball Part Number
	.900"	1-72	DL05	.015" .031" 1mm .062" 2mm .100"	210-015 210-031 210-040 210-062 210-080 210-100	210-015R 210-031R 210-040R 210-062R 210-080R 210-100R

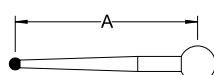
STARRETT	A (Length)	Ball Size	Model Number	Ball Diameter	Part Number
	.950"	.187" Ball	Last Word 712 715 LEVER TYPE HEAD	.015" .031" .062" .100"	213-015 213-031 213-062 213-100

TAPER-MICROMETER	A (Length)	Thread Size/Pitch	Model Number	Ball Diameter	Part Number
	.760"	2-56	Comparator TMC500	.015" .031" .062" .100"	217-015 217-031 217-062 217-100



A.G.D. & METRIC	Actual Size	A Diameter	B Length	C Radius	Thread	Part Number	
<p>RADIUS Gauging Surface</p> <p>Contact Surface Highly Polished Tungsten Carbide Unless Noted</p>		.187"	.125"	.187"	4-48 M2.5 x 0.45	301 321	
	RUBY INSERT		.187"	.125"	.187"	4-48 M2.5 x 0.45	301R 321R
		.187"	.250"	.187"	4-48 M2.5 x 0.45	302 322	
	RUBY INSERT		.187"	.250"	.187"	4-48 M2.5 x 0.45	302R 322R
		.187"	.375"	.187"	4-48 M2.5 x 0.45	303 323	
		.187"	.500"	.187"	4-48 M2.5 x 0.45	304 324	
		.187"	.750"	.187"	4-48 M2.5 x 0.45	308 328	
		.187"	1.000"	.187"	4-48 M2.5 x 0.45	309 329	
		.187"	2.000"	.187"	4-48 M2.5 x 0.45	309-2000 329-2000	
		.187"	3.000"	.187"	4-48 M2.5 x 0.45	309-3000 329-3000	



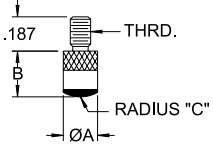

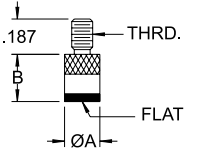





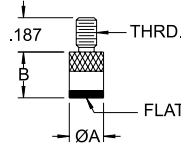
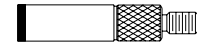

A.G.D. & METRIC RADIUS continued on page 22







A.G.D. & METRIC continued from page 21	Actual Size	A Diameter	B Length	C Radius	Thread	Part Number	
<p>RADIUS Gauging Surface</p>  <p>ØA</p> <p>THRD.</p> <p>RADIUS "C"</p> <p>B</p> <p>.187</p> <p>Contact Surface Highly Polished Tungsten Carbide Unless Noted</p>		.187"	4.000"	.187"	4-48	309-4000	
					M2.5 x 0.45	329-4000	
			.250"	.250"	.250"	4-48	310
					M2.5 x 0.45	330	
	RUBY INSERT		.250"	.250"	.250"	4-48	310R
					M2.5 x 0.45	330R	
			.281"	.140"	.312"	4-48	305
					M2.5 x 0.45	325	
			.375"	.156"	.437"	4-48	306
					M2.5 x 0.45	326	
			.500"	.187"	.562"	4-48	311
					M2.5 x 0.45	331	
			.625"	.187"	.813"	4-48	316
					M2.5 x 0.45	335	
		.750"	.218"	1.000"	4-48	319	
				M2.5 x 0.45	336		
		1.000"	.218"	1.500"	4-48	320	
				M2.5 x 0.45	339		



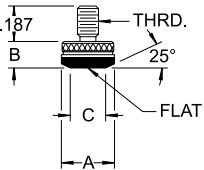

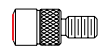
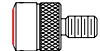
A.G.D. & METRIC	Actual Size	A Diameter	B Length	Thread	Part Number	
<p>FLAT Gauging Surface</p>  <p>ØA</p> <p>THRD.</p> <p>FLAT</p> <p>B</p> <p>.187</p> <p>Tungsten Carbide Contact Surface Unless Noted Highly Polished Lapped Flat And Parallel With Shoulder</p>		.062"	.250"	4-48	351	
				M2.5 x 0.45	371	
			.125"	.250"	4-48	352
				M2.5 x 0.45	372	
			.187"	.125"	4-48	353
				M2.5 x 0.45	373	
			.187"	.250"	4-48	354
				M2.5 x 0.45	374	
			.187"	.375"	4-48	355
				M2.5 x 0.45	375	
			.187"	.500"	4-48	356
				M2.5 x 0.45	376	

A.G.D. & METRIC FLAT continued on page 23

A.G.D. & METRIC
continued from page 22

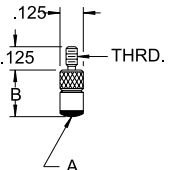
	Actual Size	A Diameter	B Length	Thread	Part Number
<p>FLAT Gauging Surface</p>  <p>Tungsten Carbide Contact Surface Unless Noted Highly Polished Lapped Flat And Parallel With Shoulder</p>		.187"	.750"	4-48	359
				M2.5 x 0.45	379
		.187"	1.000"	4-48	360
				M2.5 x 0.45	380
		.187"	2.000"	4-48	360-2000
				M2.5 x 0.45	380-2000
		.187"	3.000"	4-48	360-3000
				M2.5 x 0.45	380-3000
		.187"	4.000"	4-48	360-4000
				M2.5 x 0.45	380-4000
		.250"	.250"	4-48	361
				M2.5 x 0.45	381
		.281"	.140"	4-48	357
				M2.5 x 0.45	377
		.375"	.156"	4-48	358
				M2.5 x 0.45	378
		.500"	.187"	4-48	317
				M2.5 x 0.45	337
		.625"	.187"	4-48	365
				M2.5 x 0.45	395
	.750"	.218"	4-48	366	
			M2.5 x 0.45	396	
	1.000"	.218"	4-48	367	
			M2.5 x 0.45	398	

A.G.D. & METRIC	Actual Size	A Diameter	B Length	C Diameter	Thread	Part Number	
<p>FLAT Gauging Surface with Lead Chamfer</p>  <p>Tungsten Carbide Contact Surface Unless Noted Highly Polished Lapped Flat And Parallel With Shoulder</p>		.187"	.125	.125"	4-48	501	
					M2.5 x 0.45	511	
	RUBY INSERT		.187"	.125"	.125"	4-48	353R
					M2.5 x 0.45	373R	
	RUBY INSERT		.187"	.250"	.125"	4-48	354R
					M2.5 x 0.45	374R	
	RUBY INSERT		.250"	.250"	.177"	4-48	361R
					M2.5 x 0.45	381R	
			.281"	.140"	.187"	4-48	502
					M2.5 x 0.45	512	
			.375"	.156"	.250"	4-48	503
					M2.5 x 0.45	513	
			.500"	.187"	.375"	4-48	504
					M2.5 x 0.45	514	

ANSI Group O	Actual Size	A	B Length	Thread	Part Number
<p>Radius And Flat Gauging Surface</p>  <p>Contact Surface Highly Polished Tungsten Carbide</p>		.125" Radius	.156"	0-80	541
				1-72	552
		.125" Radius	.250"	0-80	542
				1-72	553
		Flat	.156"	0-80	543
				1-72	554
		Flat	.250"	0-80	544
				1-72	555



METRIC	Actual Size	A	B Length	Thread	Part Number
<p>Radius And Flat Gauging Surface</p> <p>Ø.170 .187 THRD. B A Contact Surface Highly Polished Tungsten Carbide</p>		.156" Radius	.250"	M2.6 x 0.45	601
		.156" Radius	.500"	M2.6 x 0.45	602
		Flat	.250"	M2.6 x 0.45	603
		Flat	.500"	M2.6 x 0.45	604
		Flat	.250"	M2.5 x 0.45	611
		Flat	.500"	M2.5 x 0.45	612





A.G.D. & METRIC	Actual Size	A Length	Thread	Part Number
<p>Flanged Contacts For Checking Grooves And Ledges</p> <p>Ø.187 .187 THRD. A .062 45° Ø.375 .010 Contact Surface Highly Polished Tungsten Carbide</p>		.250"	4-48	340
		.375"	M2.5 x 0.45	345
		.500"	4-48	341
		.500"	M2.5 x 0.45	346
		.500"	4-48	342
		.500"	M2.5 x 0.45	347

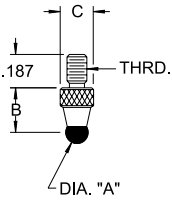
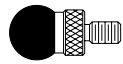
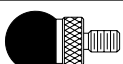
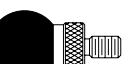



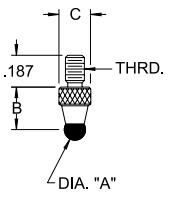
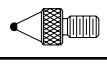
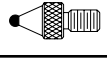
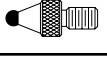
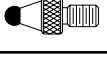
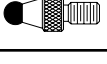
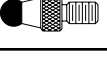
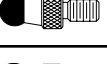
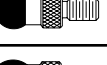
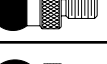

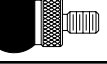
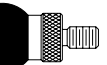
A.G.D. & METRIC	Actual Size	A Angle	B Length	Thread	Part Number
<p>Conical Sharp Point Tungsten Carbide Tipped</p> <p>Ø.187 .187 THRD. B A</p>		90°	.312"	4-48	561
		90°	.375"	M2.5 x 0.45	565
		60°	.375"	4-48	562
		60°	.375"	M2.5 x 0.45	566

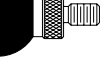

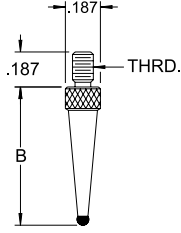
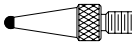

A.G.D. & METRIC	Actual Size	A Diameter	B Length	C Diameter	Thread	T.C. Ball Part Number	Ruby Ball Part Number
<p>BALL POINTS FRACTIONAL SIZE</p> <p>.187 THRD. B C DIA. "A"</p> <p>Carbide Ball is Grade 25 AFBMA Tolerance ± .0001" Sphericity .000025"</p> <p>Ruby Ball is Grade 10 AFBMA Tolerance ± .0001" Sphericity .000010"</p>		.015"	.250"	.187"	4-48	400-015	400-015R
		.015"	.250"	.187"	M2.5 x 0.45	450-015	450-015R
		.03125"	.250"	.187"	4-48	401	401R
		.03125"	.250"	.187"	M2.5 x 0.45	415	415R
		.04687"	.250"	.187"	4-48	402	402R
		.04687"	.250"	.187"	M2.5 x 0.45	416	416R
		.0625"	.250"	.187"	4-48	403	403R
		.0625"	.250"	.187"	M2.5 x 0.45	417	417R
		.09375"	.250"	.187"	4-48	404	404R
		.09375"	.250"	.187"	M2.5 x 0.45	418	418R
		.125"	.250"	.187"	4-48	405	405R
		.125"	.250"	.187"	M2.5 x 0.45	419	419R
		.15625"	.250"	.187"	4-48	406	406R
		.15625"	.250"	.187"	M2.5 x 0.45	420	420R
		.1875"	.250"	.187"	4-48	407	407R
		.1875"	.250"	.187"	M2.5 x 0.45	421	421R
	.21875"	.250"	.218"	4-48	408	408R	
	.21875"	.250"	.218"	M2.5 x 0.45	422	422R	
	.250"	.250"	.218"	4-48	409	409R	
	.250"	.250"	.218"	M2.5 x 0.45	423	423R	

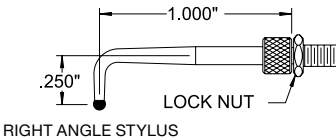

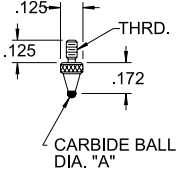

A.G.D. & METRIC FRACTIONAL SIZE continued on page 26

A.G.D. & METRIC continued from page 25	Actual Size	A Diameter	B Length	C Diameter	Thread	T.C. Ball Part Number	Ruby Ball Part Number
<p>BALL POINTS FRACTIONAL SIZE</p>  <p>Carbide Ball is Grade 25 AFBMA Tolerance $\pm .0001$" Sphericity .000025"</p> <p>Ruby Ball is Grade 10 AFBMA Tolerance $\pm .0001$" Sphericity .000010"</p>		.28125"	.250"	.234"	4-48	410	410R
					M2.5 x 0.45	424	424R
		.3125"	.250"	.250"	4-48	411	411R
					M2.5 x 0.45	425	425R
		.375"	.312"	.250"	4-48	412	412R
					M2.5 x 0.45	426	426R
		.437"	.343"	.250"	4-48	413	N/A
					M2.5 x 0.45	427	N/A
		.500"	.375"	.250"	4-48	414	N/A
					M2.5 x 0.45	428	N/A

A.G.D. & METRIC	Actual Size	A Diameter	B Length	C Diameter	Thread	T.C. Ball Part Number	Ruby Ball Part Number
<p>BALL POINTS METRIC SIZE</p>  <p>Carbide Ball is Grade 25 AFBMA Tolerance $\pm .0001$" Sphericity .000025"</p> <p>Ruby Ball is Grade 10 AFBMA Tolerance $\pm .0001$" Sphericity .000010"</p>		1mm	.250"	.187"	4-48	400-1	400-1R
					M2.5 x 0.45	450-1	450-1R
		1.5mm	.250"	.187"	4-48	400-1.5	400-1.5R
					M2.5 x 0.45	450-1.5	450-1.5R
		2mm	.250"	.187"	4-48	400-2	400-2R
					M2.5 x 0.45	450-2	450-2R
		2.5mm	.250"	.187"	4-48	400-2.5	400-2.5R
					M2.5 x 0.45	450-2.5	450-2.5R
		3mm	.250"	.187"	4-48	400-3	400-3R
					M2.5 x 0.45	450-3	450-3R
		3.5mm	.250"	.187"	4-48	400-3.5	400-3.5R
					M2.5 x 0.45	450-3.5	450-3.5R
		4mm	.250"	.187"	4-48	400-4	400-4R
					M2.5 x 0.45	450-4	450-4R
		5mm	.250"	.187"	4-48	400-5	400-5R
					M2.5 x 0.45	450-5	450-5R
		6mm	.250"	.218"	4-48	400-6	400-6R
					M2.5 x 0.45	450-6	450-6R
		7mm	.250"	.234"	4-48	400-7	400-7R
					M2.5 x 0.45	450-7	450-7R
	8mm	.250"	.250"	4-48	400-8	400-8R	
				M2.5 x 0.45	450-8	450-8R	
	9mm	.312"	.250"	4-48	400-9	400-9R	
				M2.5 x 0.45	450-9	450-9R	
	10mm	.312"	.250"	4-48	400-10	400-10R	
				M2.5 x 0.45	450-10	450-10R	
	11mm	.343"	.250"	4-48	400-11	N/A	
				M2.5 x 0.45	450-11	N/A	
	12mm	.343"	.250"	4-48	400-12	N/A	
				M2.5 x 0.45	450-12	N/A	

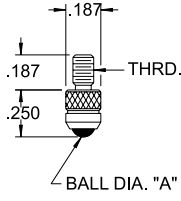



A.G.D. & METRIC	Actual Size	B Length	Thread	Ball Size	T.C Ball Part Number	Ruby Ball Part Number
<p>BALL POINTS EXTENDED TAPER</p>  <p>Carbide Ball is Grade 25 AFBMA Tolerance $\pm .0001$" Sphericity .000025"</p> <p>Ruby Ball is Grade 10 AFBMA Tolerance $\pm .0001$" Sphericity .000010"</p>		.500"	4-48	.015" .031" .062"	431-015 431-031 431-062	431-015R 431-031R 431-062R
			M2.5 x 0.45	.015" .031" .062"	436-015 436-031 436-062	436-015R 436-031R 436-062R
		.625"	4-48	.015" .031" .062"	434-015 434-031 434-062	434-015R 434-031R 434-062R
			M2.5 x 0.45	.015" .031" .062"	439-015 439-031 439-062	439-015R 439-031R 439-062R
		.750"	4-48	.015" .031" .062"	432-015 432-031 432-062	432-015R 432-031R 432-062R
			M2.5 x 0.45	.015" .031" .062"	437-015 437-031 437-062	437-015R 437-031R 437-062R
		.750"	4-48	.015"	435	N/A
			M2.5 x 0.45	.015"	445	N/A
		1.000	4-48	.015" .031" .062"	433-015 433-031 433-062	433-015R 433-031R 433-062R
			M2.5 x 0.45	.015" .031" .062"	438-015 438-031 438-062	438-015R 438-031R 438-062R
		1.000"	4-48	.031" .062" .100"	500-031 500-062 500-100	N/A
	RIGHT ANGLE STYLUS		M2.5 x 0.45	.031" .062" .100"	600-031 600-062 600-100	N/A
	1.500"	4-48	.015" .031" .062"	449-015 449-031 449-062	449-015R 449-031R 449-062R	
		M2.5 x 0.45	.015" .031" .062"	444-015 444-031 444-062	444-015R 444-031R 444-062R	

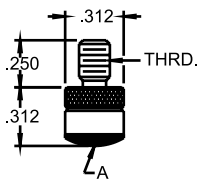
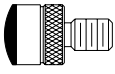
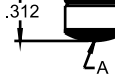
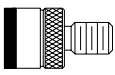

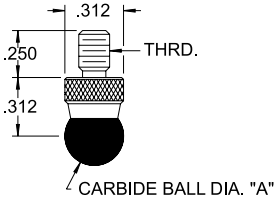
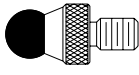
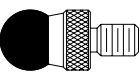
ANSI GROUP O	Actual Size	A Diameter	Thread	Part Number
<p>BALL POINTS</p>  <p>CARBIDE BALL DIA. "A"</p>		.0312"	0-80	520
			1-72	531
		.0469"	0-80	521
			1-72	532
		.0625"	0-80	522
			1-72	533
		.0937"	0-80	523
			1-72	534

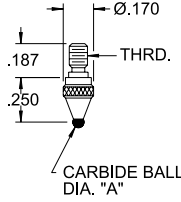
A.G.D. & METRIC	Actual Size	A Diameter	Thread	Part Number
BALL POINTS (LOW PROFILE) 		.062" Carbide	4-48	479
			M2.5 x 0.45	489
		.062" Ruby	4-48	480
			M2.5 x 0.45	490
		.125" Carbide	4-48	481
			M2.5 x 0.45	491
		.125" Ruby	4-48	482
			M2.5 x 0.45	492



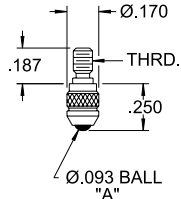

A.G.D.	Actual Size	A	Thread	Part Number
Radius & Flat Gauging Surface 		.312" Radius	8-32	581
			10-32	591
Contact Surface Highly Polished Tungsten Carbide 		Flat	8-32	582
			10-32	592

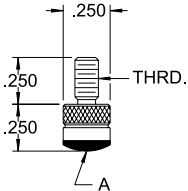
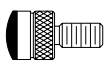
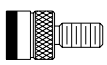

A.G.D.	Actual Size	A Diameter	Thread	Part Number
BALL POINTS 		.250"	10-32	584
			8-32	594
		.3125"	10-32	585
			8-32	595

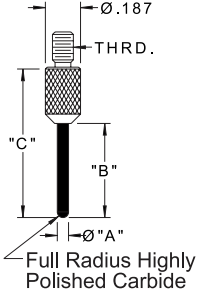
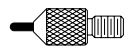
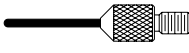
METRIC	Actual Size	A Diameter	Thread	Part Number
BALL POINTS 		.0312"	M2.6 x 0.45	620
			M2.5 x 0.45	631
		.0625"	M2.6 x 0.45	621
			M2.5 x 0.45	632
		.0937"	M2.6 x 0.45	622
			M2.5 x 0.45	633
		.125"	M2.6 x 0.45	623
			M2.5 x 0.45	634

METRIC	Actual Size	A	Thread	Part Number
BALL POINTS (LOW PROFILE) 		Carbide	M2.6 x 0.45	640
			M2.5 x 0.45	645
		Ruby	M2.6 x 0.45	641
			M2.5 x 0.45	646

A.G.D.	Actual Size	A	Thread	Part Number
Radius & Flat Gauging Surface 		.250" Radius	5-40	660
			4-40	665
Contact Surface Highly Polished Tungsten Carbide		Flat	5-40	661
			4-40	668

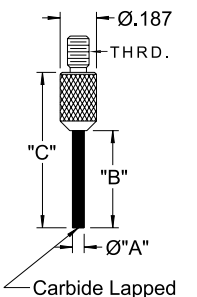
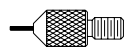
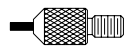
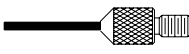
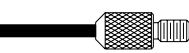
A.G.D. & METRIC	Actual Size	A Diameter	B Length	C Length	Thread	Part Number
RADIUS NEEDLE Gauging Surface  Full Radius Highly Polished Carbide		1.0mm	.120"	.400"	4-48	625
					M2.5 x 0.45	635
		1.0mm	.500"	.780"	4-48	628
					M2.5 x 0.45	638
		1.5mm	.500"	.800"	4-48	525
					M2.5 x 0.45	535
		1.5mm	1.000"	1.300"	4-48	528
					M2.5 x 0.45	538
		2.0mm	1.000"	1.300"	4-48	547
					M2.5 x 0.45	557

A.G.D. & METRIC	Actual Size	A Diameter	B Length	C Length	Thread	Part Number
FLAT NEEDLE Gauging Surface  Carbide Lapped Flat and Parallel		.018"	.120"	.400"	4-48	363
					M2.5 x 0.45	383
		1.0mm	.120"	.400"	4-48	364
					M2.5 x 0.45	384
		1.0mm	.500"	.780"	4-48	627
					M2.5 x 0.45	637
		1.5mm	.500"	.800"	4-48	314
					M2.5 x 0.45	334
		1.5mm	1.000"	1.300"	4-48	527
					M2.5 x 0.45	537
		2.0mm	1.000"	1.300"	4-48	546
					M2.5 x 0.45	556

A.G.D. & METRIC	Actual Size	A Diameter	B Length	C Length	Thread	Part Number
CONICAL SHARP POINT NEEDLE Gauging Surface Carbide Tip		1.0mm	.120"	.400"	4-48	626
		1.0mm	.500"	.780"	M2.5 x 0.45	636
		1.5mm	.500"	.800"	4-48	629
		1.5mm	.500"	.800"	M2.5 x 0.45	639
		1.5mm	1.000"	1.300"	4-48	526
		1.5mm	1.000"	1.300"	M2.5 x 0.45	536
		2.0mm	1.000"	1.300"	4-48	529
		2.0mm	1.000"	1.300"	M2.5 x 0.45	539
		2.0mm	1.000"	1.300"	4-48	548
		2.0mm	1.000"	1.300"	M2.5 x 0.45	558

A.G.D. & METRIC	Thread	Part Number
FLAT END CHISEL Carbide Tipped 	4-48	318
	M2.5 x 0.45	338
RADIUS END CHISEL Carbide Tipped 	4-48	577
	M2.5 x 0.45	587
FLAT END BLADE Carbide Tipped 	4-48	350
	M2.5 x 0.45	370
RIGHT ANGLE STYLUS CENTER For use with tips on pages 2-13 	4-48	549
	M2.5 x 0.45	559
 SR.0625 DELRIN BRASS BODY	4-48	313
	M2.5 x 0.45	333

ROLLER CONTACT		
A.G.D. & METRIC	Thread	Part Number
PRECISION HIGH SPEED BEARING 	4-48	670-375
	M2.5 x 0.45	671-375
PRECISION HIGH SPEED BEARING 	4-48	670-500
	M2.5 x 0.45	671-500

EXTENSIONS					
A.G.D. & METRIC	Actual Size	B Length	Female Thread	Male Thread	Part Number
		.250"	4-48	4-48	307-E250
			M2.5 x 0.45	M2.5 x 0.45	327-E250
		.375"	4-48	4-48	307-E375
			M2.5 x 0.45	M2.5 x 0.45	327-E375
		.500"	4-48	4-48	307-E500
			M2.5 x 0.45	M2.5 x 0.45	327-E500
		.750"	4-48	4-48	307-E750
			M2.5 x 0.45	M2.5 x 0.45	327-E750
		1.000"	4-48	4-48	307-E1000
			M2.5 x 0.45	M2.5 x 0.45	327-E1000
		2.000"	4-48	4-48	307-E2000
			M2.5 x 0.45	M2.5 x 0.45	327-E2000
		3.000"	4-48	4-48	307-E3000
			M2.5 x 0.45	M2.5 x 0.45	327-E3000
		4.000"	4-48	4-48	307-E4000
			M2.5 x 0.45	M2.5 x 0.45	327-E4000
		6.000"	4-48	4-48	307-E6000
			M2.5 x 0.45	M2.5 x 0.45	327-E6000

ADAPTORS					
A.G.D. & METRIC	Actual Size	B Length	Female Thread	Male Thread	Part Number
		.375"	M2.5 x 0.45	4-48	343-E375
			4-48	M2.5 x 0.45	344-E375
		.250"	M1.4 x 0.3	4-48	349-E250
				M2.5 x 0.45	369-E250
		.250"	M1.7 x 0.35	4-48	348-E250
				M2.5 x 0.45	368-E250
		.250"	M2.0 x 0.4	4-48	429-E250
				M2.5 x 0.45	430-E250

M2 THREADED STYLI







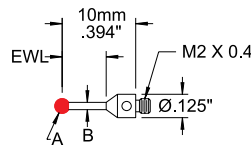

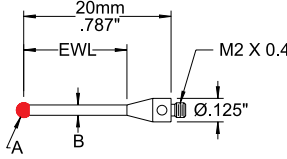

Ruby and Carbide Ball Styli

10.0mm Range Length

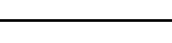
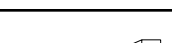

Actual Size	A Ball Size	B Stem Dia.	EWL	Stem Material	Ball Material	Part Number
	0.3mm .012"	0.23mm .009"	2.0mm .079"	Tungsten Carbide	Ruby	265-.3R
					Carbide	265-.3
	0.5mm .020"	0.38mm .015"	3.0mm .118"	Tungsten Carbide	Ruby	265-.5R
					Carbide	265-.5
	0.7mm .028"	0.50mm .020"	4.0mm .157"	Tungsten Carbide	Ruby	265-.7R
					Carbide	265-.7
	1.0mm .039"	0.71mm .028"	4.5mm .177"	Stainless Steel	Ruby	265-1R
					Carbide	265-1
	1.5mm .059"	0.71mm .028"	4.5mm .177"	Stainless Steel	Ruby	265-1.5R
					Carbide	265-1.5
	2.0mm .079"	1.00mm .039"	6.0mm .236"	Stainless Steel	Ruby	265-2R
					Carbide	265-2
	2.5mm .098"	1.00mm .039"	6.0mm .236"	Stainless Steel	Ruby	265-2.5R
					Carbide	265-2.5
	3.0mm .118"	1.50mm .059"	5.0mm .197"	Stainless Steel	Ruby	265-3R
					Carbide	265-3

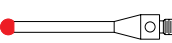
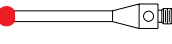
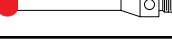
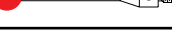
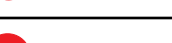
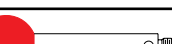
Ruby and Carbide Ball Styli						10.0mm Range Length	
continued from page 32							
Actual Size	A Ball Size	B Stem Dia.	EWL	Stem Material	Ball Material	Part Number	
	4.0mm .157"	2.0mm .079"	5.0mm .197"	Stainless Steel	Ruby	265-4R	
					Carbide	265-4	
	5.0mm .197"	2.50mm .098"	7.3mm .286"	Stainless Steel	Ruby	265-5R	
					Carbide	265-5	
	6.0mm .236"	2.50mm .098"	7.3mm .286"	Stainless Steel	Ruby	265-6R	
					Carbide	265-6	
12.0mm Range Length 	8.0mm .315"	3.2mm .125"	12.0mm .472"	Stainless Steel	Ruby	265-8R	
					Carbide	265-8	

Ruby and Carbide Ball Styli						20.0mm Range Length	
							
Actual Size	A Ball Size	B Stem Dia.	EWL	Stem Material	Ball Material	Part Number	
	0.3mm .012"	0.23mm .009"	2.0mm .079"	Tungsten Carbide	Ruby	266-.3R	
					Carbide	266-.3	
	0.5mm .020"	0.38mm .015"	3.0mm .118"	Tungsten Carbide	Ruby	266-.5R	
					Carbide	266-.5	
	0.5mm .020"	0.38mm .015"	7.0mm .276"	Tungsten Carbide	Ruby	266-.5RL	
					Carbide	266-.5L	
	0.7mm .028"	0.50mm .020"	4.0mm .157"	Tungsten Carbide	Ruby	266-.7R	
					Carbide	266-.7	
	0.7mm .028"	0.50mm .020"	12.0mm .472"	Tungsten Carbide	Ruby	266-.7RL	
					Carbide	266-.7L	
	1.0mm .039"	0.71mm .028"	7.0mm .276"	Stainless Steel	Ruby	266-1R	
					Carbide	266-1	
	1.0mm .039"	0.79mm .031"	15.0mm .591"	Tungsten Carbide	Ruby	266-1RL	
					Carbide	266-1L	
	1.5mm .059"	1.07mm .042"	8.0mm .315"	Stainless Steel	Ruby	266-1.5R	
					Carbide	266-1.5	
	1.5mm .059"	1.0mm .039"	15mm .591"	Tungsten Carbide	Ruby	266-1.5RL	
					Carbide	266-1.5L	
	2.0mm .079"	1.40mm .055"	14.0mm .551"	Stainless Steel	Ruby	266-2R	
					Carbide	266-2	
	2.5mm .098"	1.40mm .055"	14.0mm .551"	Stainless Steel	Ruby	266-2.5R	
					Carbide	265-2.5	
	3.0mm .118"	1.50mm .059"	15.0mm .591"	Stainless Steel	Ruby	266-3R	
					Carbide	266-3	
	4.0mm .157"	2.0mm .079"	15.0mm .591"	Stainless Steel	Ruby	266-4R	
					Carbide	266-4	
	5.0mm .197"	2.5mm .098"	17.2mm .679"	Stainless Steel	Ruby	266-5R	
					Carbide	266-5	
	6.0mm .236"	2.5mm .098"	17.2mm .679"	Stainless Steel	Ruby	266-6R	
					Carbide	266-6	
	8.0mm .315"	3.2mm .125"	20.0mm .787"	Stainless Steel	Ruby	266-8R	
					Carbide	266-8	





M2 THREADED STYLI







Ruby Ball Styli		30.0mm Range Length			
Actual Size	A Ball Size	B Stem Dia.	EWL	Stem Material	Part Number
	1.0mm .039"	0.79mm .031"	25.0mm .984"	Tungsten Carbide	801-1R
	1.5mm .059"	1.00mm .039"	25.0mm .984"	Tungsten Carbide	801-1.5R
	2.0mm .079"	1.50mm .059"	25.0mm .984"	Tungsten Carbide	801-2R
	2.5mm .098"	2.00mm .079"	25.0mm .984"	Tungsten Carbide	801-2.5R
	3.0mm .118"	2.00mm .079"	25.0mm .984"	Tungsten Carbide	801-3R
	3.0mm .118"	2.38mm .093"	25.0mm	Carbon Fiber	9230-3R
	4.0mm .157"	2.00mm .079"	25.0mm .984"	Tungsten Carbide	801-4R
	4.0mm .157"	3.18mm .125"	30.0mm	Carbon Fiber	9230-4R
	5.0mm .197"	2.38mm .093"	23.7mm .932"	Tungsten Carbide	801-5R
	5.0mm .197"	3.18mm .125"	30.0mm	Carbon Fiber	9230-5R
	6.0mm .236"	3.18mm .125"	30.0mm	Carbon Fiber	9230-6R

Ruby Ball Styli		40.0mm Range Length			
Actual Size	A Ball Size	B Stem Dia.	EWL	Stem Material	Part Number
	2.0mm .079"	1.50mm .059"	35.0mm 1.378"	Tungsten Carbide	802-2R
	2.5mm .098"	2.00mm .079"	35.0mm 1.378"	Tungsten Carbide	802-2.5R
	3.0mm .118"	2.00mm .079"	35.0mm 1.378"	Tungsten Carbide	802-3R
	3.0mm .118"	2.38mm .093"	35.0mm 1.378"	Carbon Fiber	9240-3R
	4.0mm .157"	2.00mm .079"	35.0mm 1.378"	Tungsten Carbide	802-4R

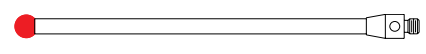
Ruby and Carbide Ball Styli - 40.0mm Range Length

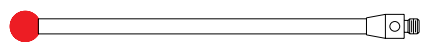
continued on page 35

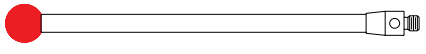
Ruby Ball Styli		40.0mm Range Length			
continued from page 34					
Actual Size	A Ball Size	B Stem Dia.	EWL	Stem Material	Part Number
	4.0mm .157"	3.18mm .125"	40.0mm 1.575"	Carbon Fiber	9240-4R
	5.0mm .197"	2.38mm .093"	33.7mm 1.326"	Tungsten Carbide	802-5R
	5.0mm .197"	3.18mm .125"	40.0mm 1.575"	Carbon Fiber	9240-5R
	6.0mm .236"	3.18mm .125"	40.0mm 1.575"	Carbon Fiber	9240-6R

Ruby Ball Styli		50.0mm Range Length			
Actual Size	A Ball Size	B Stem Dia.	EWL	Stem Material	Part Number
	3.0mm .118"	2.00mm .079"	45.0mm 1.772"	Tungsten Carbide	803-3R
	3.0mm .118"	2.38mm .093"	45.0mm 1.772"	Ceramic	804-3R
	3.0mm .118"	2.38mm .093"	43.7mm 1.720"	Carbon Fiber	9250-3R
	4.0mm .157"	2.00mm .079"	45.0mm 1.772"	Tungsten Carbide	803-4R
	4.0mm .157"	2.38mm .093"	43.7mm 1.720"	Ceramic	804-4R
	4.0mm .157"	3.18mm .125"	50.0mm 1.969"	Carbon Fiber	9250-4R
	5.0mm .197"	2.38mm .093"	43.7mm 1.720"	Tungsten Carbide	803-5R
	5.0mm .197"	2.38mm .093"	43.7mm 1.720"	Ceramic	804-5R
	5.0mm .197"	3.18mm .125"	50.0mm 1.969"	Carbon Fiber	9250-5R
	6.0mm .236"	3.18mm .125"	50.0mm 1.969"	Carbon Fiber	9250-6R

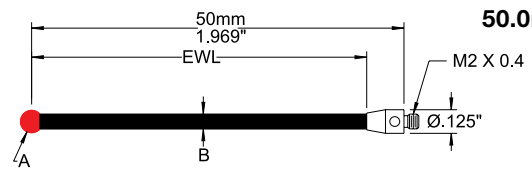

M2 THREADED STYLI

Ruby Ball Styli		75.0mm Range Length				
Actual Size	A Ball Size	B Stem Dia.	EWL	Stem Material	Part Number	
	4.0mm .157"	3.18mm .125"	75.0mm 2.953"	Carbon Fiber	9275-4R	
	5.0mm .197"	3.18mm .125"	75.0mm 2.953"	Carbon Fiber	9275-5R	
	6.0mm .236"	3.18mm .125"	75.0mm 2.953"	Carbon Fiber	9275-6R	

Ruby Ball Styli		100.0mm Range Length				
Actual Size	A Ball Size	B Stem Dia.	EWL	Stem Material	Part Number	
	4.0mm .157"	3.18mm .125"	100.0mm 3.937"	Carbon Fiber	92100-4R	
	5.0mm .197"	3.18mm .125"	100.0mm 3.937"	Carbon Fiber	92100-5R	
	6.0mm .236"	3.18mm .125"	100.0mm 3.937"	Carbon Fiber	92100-6R	

Pointer Styli – Tungsten Carbide Tip		Part Number
		388
		269

Ruby Star Styli – Stationary		
Actual Size	Ball Size	Part Number
	2.0mm .079"	265-A
	2.0mm .079"	266-A
		265-0

Ruby Star Styli – Adjustable		
Actual Size	Ball Size	Part Number
	1.0mm .039"	830
	2.0mm .079"	386
	2.0mm .079"	387
	2.0mm .079"	385
<p>Common Center Stylus for 386 & 387 Star Styli</p>		
		278
<p>Adjustable 5 Way Stylus Center</p>		
		819
<p>Adjustable 4 Way Stylus Center</p>		
		278CP
<p>Common Center Post for 278 Stylus Centers</p>		

M2 THREADED STYLI

Disk Styli – Hardened Tool Steel	
Actual Size	Part Number
	831
	832
	833
	828
	829
	834





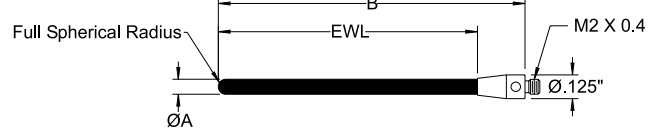
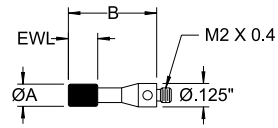

Disk Styli – Hardened Tool Steel	
Actual Size	Part Number
	270
	827
	271
	826
	272
	813
	814

Cylinder Styli



Actual Size	A Diameter	EWL	B Length	Cylinder Material	Part Number
	1.5mm .059"	1.0mm .039"	10.75mm .423"	Carbide	267
	3.0mm .118"	3.5mm .138"	12mm .472"	Carbide	268
	0.3mm .012"	3.0mm .118"	10mm .394"	Carbide	708
	0.5mm .020"	8.0mm .315"	15mm .590"	Carbide	709
	1.0mm .039"	8.5mm .335"	15.5mm .610"	Ruby	815R
	1.5mm .059"	8.75mm .344"	15.75mm .620"	Ruby	816R
	2.0mm .079"	7.2mm .283"	21mm .827"	Ruby	382R
				Carbide	382
	4.0mm .157"	10mm .394"	22mm .866"	Ruby	817R
	1.0mm .039"	14.15mm .557"	20.5mm .807"	Steel	710-20
				Carbide	710-20C
	1.5mm .059"	14.4mm .567"	20.75mm .817"	Steel	711-20
				Carbide	711-20C
	2.0mm .079"	14.65mm .577"	21mm .827"	Steel	712-20
				Carbide	712-20C
	1.0mm .039"	34.15mm 1.345"	40.5mm 1.595"	Steel	710-40
				Carbide	710-40C
	1.5mm .059"	34.4mm 1.354"	40.75mm 1.604"	Steel	711-40
				Carbide	711-40C
	2.0mm .079"	34.65mm 1.364"	41mm 1.614"	Steel	712-40
				Carbide	712-40C

M2 THREADED STYLI

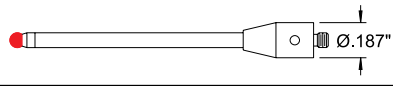
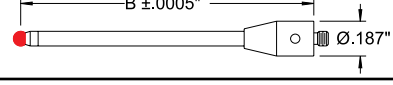
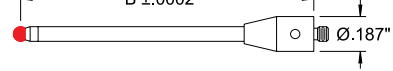
Precision Ball Cylinder Styli					
Actual Size	A Ball Size	B Length	EWL	Cylinder Material	Part Number
	1.0mm .039" Carbide	20.0mm .787"	13.65mm .537"	Carbide	714-20C
	1.0mm .039" Carbide	40.0mm 1.575"	33.65mm 1.325"	Carbide	714-40C
	1.5mm .059" Carbide	20.0mm .787"	13.65mm .537"	Carbide	715-20C
	1.5mm .059" Carbide	40.0mm 1.575"	33.65mm 1.325"	Carbide	715-40C
	2.0mm .079" Carbide	20.0mm .787"	13.65mm .537"	Carbide	716-20C
	2.0mm .079" Carbide	40.0mm 1.575"	33.65mm 1.325"	Carbide	716-40C
	2.0mm .079" Ruby	40.0mm 1.575"	30.5mm 1.201"	Ceramic	292
	2.0mm .079" Ruby	40.0mm 1.575"	30.5mm 1.201"	Ceramic	291
	2.0mm .079" Ruby	40.0mm 1.575"	30.5mm 1.201"	Ceramic	290

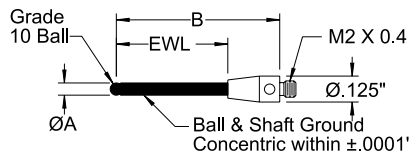



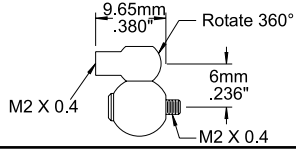
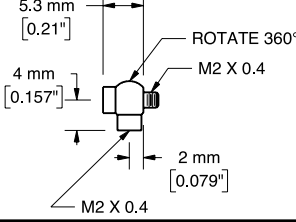
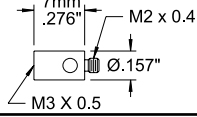
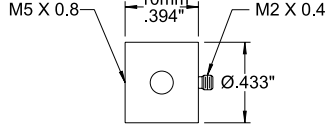
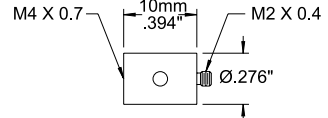



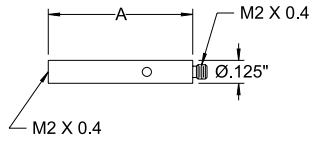

Shaft Diameter Ground within ±.0001 of Ball Diameter

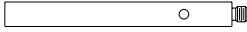
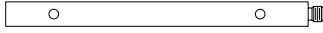

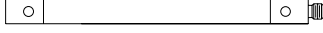
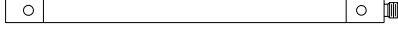
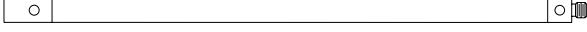

Adapters	
Actual Size	Part Number
<p>Adjustable Stylus Knuckle</p> 	277
<p>Adjustable 90° Right Angle Adaptor</p> 	265-RA4
	265-AD7
	6013
	6014

Stylus Extensions











Actual Size	A Length	Material	Part Number
	5.0mm .196"	Stainless Steel	265-E5
	10.0mm .394"	Stainless Steel	265-E10
	20.0mm .787"	Stainless Steel	265-E20
	30.0mm 1.181"	Stainless Steel	265-E30
	40.0mm 1.575"	Stainless Steel	265-E40
	60.0mm 2.362"	Stainless Steel	265-E60
	90.0mm 3.543"	Stainless Steel	265-E90
	30.0mm 1.181"	Ceramic	265-EC30
	40.0mm 1.575"	Ceramic	265-EC40
	50.0mm 1.969"	Ceramic	265-EC50
	75.0mm 2.953"	Ceramic	265-EC75
	100.0mm 3.937"	Ceramic	265-EC100

Extensions with Carbon Fiber Shaft

	A Length	B Shaft Diameter	Shaft Material	Threaded Ends Material	Part Number
	30.0mm 1.181"	3.18mm .125"	Carbon Fiber	Stainless Steel	9202-E30
	40.0mm 1.575"	3.18mm .125"	Carbon Fiber	Stainless Steel	9202-E40
	50.0mm 1.969"	3.18mm .125"	Carbon Fiber	Stainless Steel	9202-E50
	75.0mm 2.953"	3.18mm .125"	Carbon Fiber	Stainless Steel	9202-E75
	100.0mm 3.937"	3.18mm .125"	Carbon Fiber	Stainless Steel	9202-E100

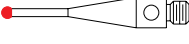
M3 THREADED STYLI

CMM REPLACEMENT STYLI

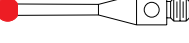
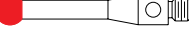
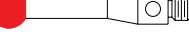
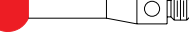
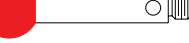
Ruby and Carbide Ball Styli				21.0mm Range Length		
Actual Size	A Ball Size	B Stem Dia.	EWL	Stem Material	Ball Material	Part Number
	0.3mm .012"	0.23mm .009"	2.0mm .079"	Tungsten Carbide	Ruby	261-3R
					Carbide	261-.3
	0.5mm .020"	0.38mm .015"	3.0mm .118"	Tungsten Carbide	Ruby	261-.5R
					Carbide	261-.5
	0.7mm .028"	0.50mm .020"	4.0mm .157"	Tungsten Carbide	Ruby	261-.7R
					Carbide	261-.7
	1.0mm .039"	0.71mm .028"	4.0mm .157"	Stainless Steel	Ruby	261-1R
					Carbide	261-1
	1.0mm .039"	0.79mm .031"	15.0mm .591"	Tungsten Carbide	Ruby	261-1RL
					Carbide	261-1L
	1.5mm .059"	1.04mm .041"	8.0mm .315"	Stainless Steel	Ruby	261-1.5R
					Carbide	261-1.5
	1.5mm .059"	1.0mm .039"	13.5mm .532"	Tungsten Carbide	Ruby	261-1.5RL
					Carbide	261-1.5L
	2.0mm .079"	1.40mm .055"	8.0mm .315"	Stainless Steel	Ruby	261-2R
					Carbide	261-2
	2.0mm .079"	1.50mm .059"	13.5mm .532"	Tungsten Carbide	Ruby	261-2RL
					Carbide	261-2L
	2.5mm .098"	2.0mm .079"	13.5mm .532"	Tungsten Carbide	Ruby	261-2.5RL
					Carbide	261-2.5L
	3.0mm .118"	1.50mm .059"	12.0mm .472"	Stainless Steel	Ruby	261-3R
					Carbide	261-3
	4.0mm .157"	2.50mm .098"	13.0mm .512"	Stainless Steel	Ruby	261-4R
					Carbide	261-4
	5.0mm .197"	2.50mm .098"	13.0mm .512"	Stainless Steel	Ruby	261-5R
					Carbide	261-5
	6.0mm .236"	2.50mm .098"	13.0mm .512"	Stainless Steel	Ruby	261-6R
					Carbide	261-6
	8.0mm .315"	4.0mm .157"	21.0mm .827"	Stainless Steel	Ruby	261-8R
					Carbide	261-8

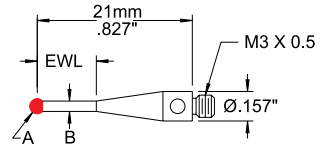

Ruby Ball Styli **31.0mm Range Length**

Actual Size	A Ball Size	B Stem Dia.	EWL	Stem Material	Ball Material	Part Number
	4.0mm .157"	2.50mm .098"	21.0mm .827"	Stainless Steel	Ruby	261-L4R
					Carbide	261-L4
	5.0mm .197"	2.50mm .098"	21.0mm .827"	Stainless Steel	Ruby	261-L5R
					Carbide	261-L5

Ruby Ball Styli **30.0mm Range Length**

Actual Size	A Ball Size	B Stem Dia.	EWL	Stem Material	Part Number
	1.5mm .059"	1.00mm .039"	22.5mm .886"	Tungsten Carbide	805-1.5R
	2.0mm .079"	1.50mm .059"	22.5mm .886"	Tungsten Carbide	805-2R
	2.5mm .098"	2.0mm .079"	22.5mm .886"	Tungsten Carbide	805-2.5R
	3.0mm .118"	2.0mm .079"	22.5mm .886"	Tungsten Carbide	805-3R

Ruby Ball Styli **40.0mm Range Length**

Actual Size	A Ball Size	B Stem Dia.	EWL	Stem Material	Part Number
	2.0mm .079"	1.50mm .059"	32.5mm 1.280"	Tungsten Carbide	806-2R
	2.5mm .098"	2.0mm .079"	32.5mm 1.280"	Tungsten Carbide	806-2.5R
	3.0mm .118"	2.0mm .079"	32.5mm 1.280"	Tungsten Carbide	806-3R
	4.0mm .157"	2.0mm .079"	32.5mm 1.280"	Tungsten Carbide	806-4R
	5.0mm .197"	2.38mm .093"	32.5mm 1.280"	Tungsten Carbide	806-5R

M3 THREADED STYLI

Ruby Ball Styli		50.0mm Range Length			
Actual Size	A Ball Size	B Stem Dia.	EWL	Stem Material	Part Number
	3.0mm .118"	2.0mm .079"	42.5mm 1.673"	Tungsten Carbide	807-3R
	3.0mm .118"	2.38mm .093"	42.5mm 1.673"	Ceramic	808-3R
	3.0mm .118"	2.38mm .093"	42.5mm 1.673"	Carbon Fiber	9350-3R
	4.0mm .157"	2.0mm .079"	42.5mm 1.673"	Tungsten Carbide	807-4R
	4.0mm .157"	2.38mm .093"	42.5mm 1.673"	Ceramic	808-4R
	4.0mm .157"	2.38mm .093"	42.5mm 1.673"	Carbon Fiber	9350-4R
	5.0mm .197"	2.38mm .093"	42.5mm 1.673"	Tungsten Carbide	807-5R
	5.0mm .197"	2.38mm .093"	42.5mm 1.673"	Ceramic	808-5R
	5.0mm .197"	2.38mm .093"	42.5mm 1.673"	Carbon Fiber	9350-5R









Ruby Ball Styli		75.0mm Range Length			
Actual Size	A Ball Size	B Stem Dia.	EWL	Stem Material	Part Number
	6.0mm .236"	4.0mm .157"	75.0mm 2.953"	Carbon Fiber	9375-6R
	8.0mm .315"	4.0mm .157"	75.0mm 2.953"	Carbon Fiber	9375-8R
	10.0mm .394"	4.0mm .157"	75.0mm 2.953"	Carbon Fiber	9375-10R

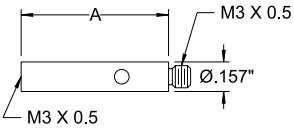

Ruby Ball Styli		100.0mm Range Length			
Actual Size	A Ball Size	B Stem Dia.	EWL	Stem Material	Part Number
	6.0mm .236"	4.0mm .157"	100.0mm 3.937"	Carbon Fiber	93100-6R
	8.0mm .315"	4.0mm .157"	100.0mm 3.937"	Carbon Fiber	93100-8R
	10.0mm .394"	4.0mm .157"	100.0mm 3.937"	Carbon Fiber	93100-10R
	12.0mm .472"	4.0mm .157"	100.0mm 3.937"	Carbon Fiber	93100-12R

Ruby Ball Styli		150.0mm Range Length			
Actual Size	A Ball Size	B Stem Dia.	EWL	Stem Material	Part Number
	10.0mm .394"	4.0mm .157"	150.0mm 5.905"	Carbon Fiber	93150-10R
	12.0mm .472"	4.0mm .157"	150.0mm 5.905"	Carbon Fiber	93150-12R

Ruby Ball Styli		200.0mm Range Length			
Actual Size	A Ball Size	B Stem Dia.	EWL	Stem Material	Part Number
	10.0mm .394"	4.0mm .157"	200.0mm 7.874"	Carbon Fiber	93200-10R
	12.0mm .472"	4.0mm .157"	200.0mm 7.874"	Carbon Fiber	93200-12R

M3 THREADED STYLI

Stylus Extensions			
			
Actual Size	A Length	Material	Part Number
	10.0mm .394"	Stainless Steel	261-E10
	20.0mm .787"	Stainless Steel	261-E20
	30.0mm 1.181"	Stainless Steel	261-E30
	35.0mm 1.378"	Stainless Steel	261-E35
	50.0mm 1.969"	Ceramic	261-EC50
	75.0mm 2.953"	Ceramic	261-EC75
	100.0mm 3.937"	Ceramic	261-EC100

Extensions with Carbon Fiber Shaft					
	A Length	B Shaft Diameter	Shaft Material	Threaded Ends Material	Part Number
	50.0mm 1.969"	4.0mm .157"	Carbon Fiber	Stainless Steel	9303-E50
	75.0mm 2.953"	4.0mm .157"	Carbon Fiber	Stainless Steel	9303-E75
	100.0mm 3.937"	4.0mm .157"	Carbon Fiber	Stainless Steel	9303-E100

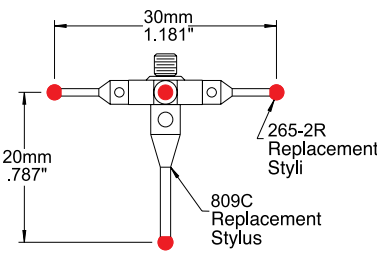
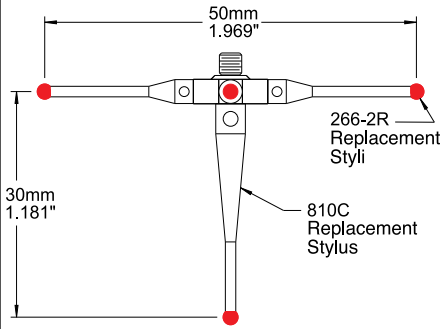
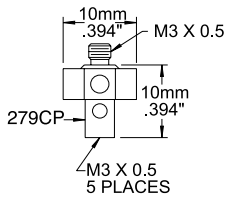
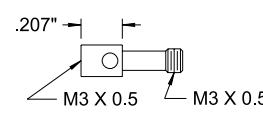
Ruby Star Styli – Adjustable		
Actual Size	Ball Size	Part Number
 <p>30mm 1.181"</p> <p>20mm .787"</p> <p>265-2R Replacement Styli</p> <p>809C Replacement Stylus</p>	2.0mm .079"	809
 <p>50mm 1.969"</p> <p>30mm 1.181"</p> <p>266-2R Replacement Styli</p> <p>810C Replacement Stylus</p>	2.0mm .079"	810
 <p>10mm .394"</p> <p>M3 X 0.5</p> <p>279CP</p> <p>10mm .394"</p> <p>M3 X 0.5 5 PLACES</p>		279
<p>5 Way Adjustable Stylus Center</p>		
 <p>.207"</p> <p>M3 X 0.5</p> <p>M3 X 0.5</p>		279CP
<p>Center Post for 279 Stylus Center</p>		

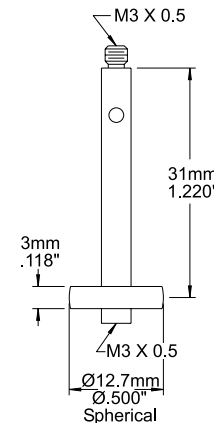
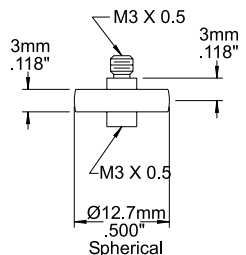
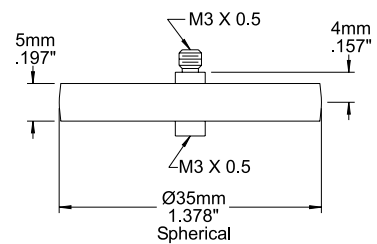
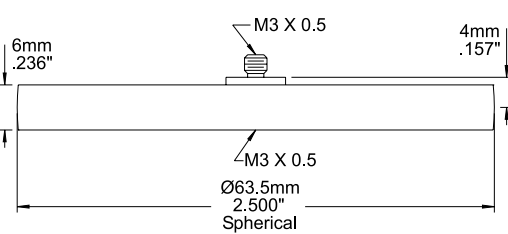
Disc Styli		Part Number
Actual Size		
 <p>M3 X 0.5</p> <p>31mm 1.220"</p> <p>3mm .118"</p> <p>M3 X 0.5</p> <p>Ø12.7mm Ø.500"</p> <p>Spherical</p>		273
 <p>M3 X 0.5</p> <p>3mm .118"</p> <p>3mm .118"</p> <p>M3 X 0.5</p> <p>Ø12.7mm .500"</p> <p>Spherical</p>		283
 <p>M3 X 0.5</p> <p>5mm .197"</p> <p>4mm .157"</p> <p>M3 X 0.5</p> <p>Ø35mm 1.378"</p> <p>Spherical</p>		284
 <p>M3 X 0.5</p> <p>6mm .236"</p> <p>4mm .157"</p> <p>M3 X 0.5</p> <p>Ø63.5mm 2.500"</p> <p>Spherical</p>		285

M3 THREADED STYLI

CMM REPLACEMENT STYLI

Adapters		Part Number
Actual Size		
	261-AD5	
	6015	
	6016	
	282	
	281	
Adjustable Offset Stylus Knuckle		
	276	
Adjustable Stylus Knuckle		
	261-RA5	
Adjustable 90° Right Angle Adaptor		
	394	
5 Way Stationary Stylus Center		

Ruby Ball Styli		20.0mm Range Length			
Actual Size	A Ball Size	B Stem Dia.	EWL	Stem Material	Part Number
	1.0mm .039"	0.76mm .030"	5.0mm .197"	Stainless Steel	840-1R
	2.0mm .079"	1.40mm .055"	9.0mm .354"	Stainless Steel	840-2R
	3.0mm .118"	1.75mm .069" (Tapered)	15.0mm .591"	Stainless Steel	840-3R
	4.0mm .157"	3.10mm .122"	15.0mm .591"	Stainless Steel	840-4R
	5.0mm .197"	3.60mm .142"	15.0mm .591"	Stainless Steel	840-5R
	6.0mm .236"	4.60mm .181"	16.0mm .630"	Stainless Steel	840-6R
	8.0mm .315"	6.1mm .240"	16.5mm .651"	Stainless Steel	840-8R

Ruby Ball Styli		Assorted Range Lengths				
Actual Size	A Ball Size	B Stem Dia.	C Length	EWL	Stem Material	Part Number
	5.0mm .197"	3.0mm .118"	10.0mm .394"	5.0mm .197"	Stainless Steel	841-5R
	5.0mm .197"	3.0mm .118"	20.0mm .787"	15.0mm .591"	Stainless Steel	842-5R
	5.0mm .197"	3.0mm .118"	30.0mm 1.181"	25.0mm .984"	Stainless Steel	843-5R

M4 THREADED STYLI

**Ruby Ball Styli
50.0mm Range Length**

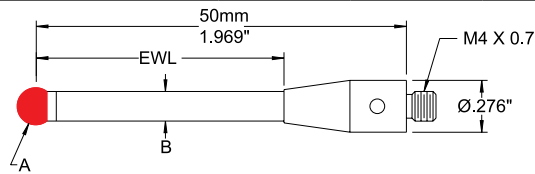

Actual Size	A Ball Size	B Stem Dia.	EWL	Stem Material	Part Number
	5.0mm .197"	3.95mm .156"	33.5mm 1.319"	Ceramic	811-5R
	5.0mm .197"	4.0mm .157"	33.5mm 1.319"	Carbon Fiber	9450-5R
	6.0mm .236"	4.75mm .187"	33.5mm 1.319"	Ceramic	811-6R
	6.0mm .236"	4.76mm .187"	33.5mm 1.319"	Carbon Fiber	9450-6R
	8.0mm .315"	4.75mm .187"	35.5mm 1.319"	Ceramic	811-8R
	8.0mm .315"	4.76mm .187"	33.5mm 1.319"	Carbon Fiber	9450-8R
	6.0mm .236"	4.75mm .187"	33.5mm 1.319"	Ceramic	811-L6R
	6.0mm .236"	4.76mm .187"	33.5mm 1.319"	Carbon Fiber	9450-L6R

**Ruby Ball Styli
100.0mm Range Length**

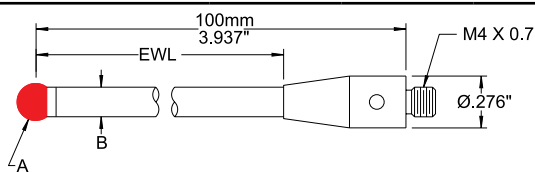

Actual Size	A Ball Size	B Stem Dia.	EWL	Stem Material	Part Number
	5.0mm .197"	3.95mm .156"	83.5mm 3.287"	Ceramic	812-5R
	5.0mm .197"	4.0mm .157"	83.5mm 3.287"	Carbon Fiber	94100-5R
	6.0mm .236"	4.75mm .187"	83.5mm 3.287"	Ceramic	812-6R
	6.0mm .236"	4.76mm .187"	83.5mm 3.287"	Carbon Fiber	94100-6R
	8.0mm .315"	4.75mm .187"	83.5mm 3.287"	Ceramic	812-8R
	8.0mm .315"	4.76mm .187"	83.5mm 3.287"	Carbon Fiber	94100-8R
	6.0mm .236"	4.75mm .187"	83.5mm 3.287"	Ceramic	812-L6R
	6.0mm .236"	4.76mm .187"	83.5mm 3.287"	Carbon Fiber	94100-L6R

**Ruby Ball Styli
150mm Range Length**

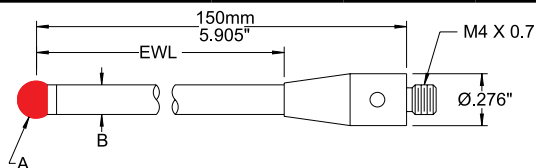

Actual Size	A Ball Size	B Stem Dia.	EWL	Stem Material	Part Number
	5.0mm .197"	3.95mm .156"	133.5mm 5.256"	Ceramic	820-5R
	5.0mm .197"	4.0mm .157"	133.5mm 5.256"	Carbon Fiber	94150-5R
	6.0mm .236"	4.75mm .187"	133.5mm 5.256"	Ceramic	820-6R
	6.0mm .236"	4.76mm .187"	133.5mm 5.256"	Carbon Fiber	94150-6R
	8.0mm .315"	4.75mm .187"	135.5mm 5.256"	Ceramic	820-8R
	8.0mm .315"	4.76mm .187"	133.5mm 5.256"	Carbon Fiber	94150-8R
	6.0mm .236"	4.75mm .187"	133.5mm 5.256"	Ceramic	820-L6R
	6.0mm .236"	4.76mm .187"	133.5mm 5.256"	Carbon Fiber	94150-L6R

**Ruby Ball Styli
200mm Range Length**

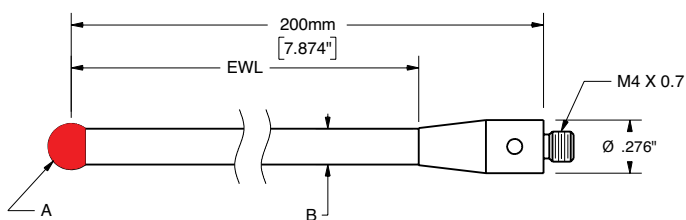

Actual Size	A Ball Size	B Stem Dia.	EWL	Stem Material	Part Number
	6.0mm .236"	4.76mm .187"	183.5mm 7.224"	Carbon Fiber	94200-6R
	8.0mm .315"	4.76mm .187"	183.5mm 7.224"	Carbon Fiber	94200-8R

**Ruby Ball Styli
300mm Range Length**

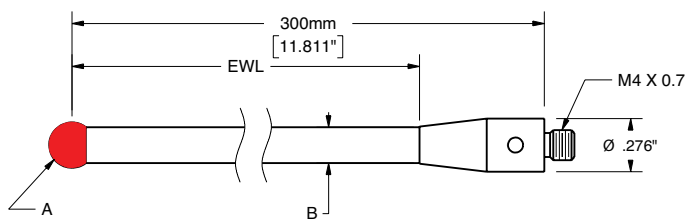







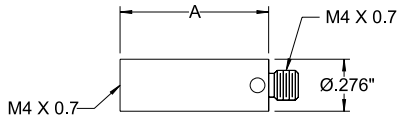

Actual Size	A Ball Size	B Stem Dia.	EWL	Stem Material	Part Number
	6.0mm .236"	4.76mm .187"	283.5mm 11.161"	Carbon Fiber	94300-6R
	8.0mm .315"	4.76mm .187"	283.5mm 11.161"	Carbon Fiber	94300-8R

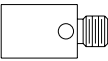
M4 THREADED STYLI

Star Stylus Centers – Adjustable		Part Number
Actual Size		
<p>5-way Adjustable Stylus Center for use with 811-L6R, 812-L6R, and 820-L6R Center Styli</p>	850	
<p>5-way Adjustable Stylus Center</p>	818	
<p>Center Post for 818 Stylus Center</p>	818CP	

Stylus Extensions







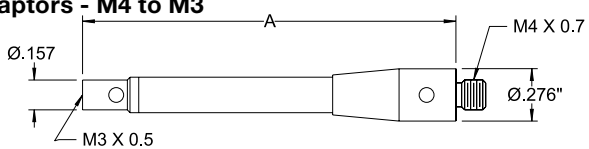
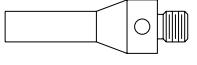

Actual Size	A Length	Material	Part Number
	10.0mm .394"	Stainless Steel	823-E10
	12.7mm .500"	Stainless Steel	823-E12.7
	15.0mm .591"	Stainless Steel	823-E15
	20.0mm .787"	Stainless Steel	823-E20
	30.0mm 1.181"	Stainless Steel	823-E30
	30.0mm 1.181"	Ceramic	823-EC30
	50.0mm 1.968"	Ceramic	823-EC50
	100.0mm 3.937"	Ceramic	823-EC100

Extensions with Carbon Fiber Shaft

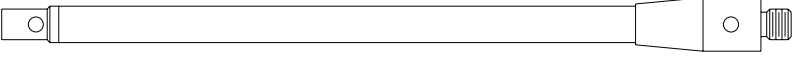
	A Length	B Shaft Diameter	Shaft Material	Threaded Ends Material	Part Number
	30.0mm 1.181"	6.35mm .250"	Carbon Fiber	Stainless Steel	9404-E30
	50.0mm 1.969"	6.35mm .250"	Carbon Fiber	Stainless Steel	9404-E50
	100.0mm 3.937"	6.35mm .250"	Carbon Fiber	Stainless Steel	9404-E100

M4 THREADED STYLI

Stylus Extensions/Adaptors - M4 to M3			
Actual Size	A Length	Stem Material	Part Number
			
	20.0mm .787"	Stainless Steel	824-E20
	50.0mm 1.969"	Ceramic	824-EC50
	75.0mm 2.953"	Ceramic	824-EC75
	100.0mm 3.937"	Ceramic	824-EC100

Stylus Extensions/Adaptors - M4 to M3 Carbon Fiber Shaft					
	A Length	B Shaft Diameter	Shaft Material	Threaded Ends Material	Part Number
	50.0mm 1.969"	4.76mm .187"	Carbon Fiber	Stainless Steel	9403-E50
	75.0mm 2.953"	4.76mm .187"	Carbon Fiber	Stainless Steel	9403-E75
	100.0mm 3.937"	4.76mm .187"	Carbon Fiber	Stainless Steel	9403-E100

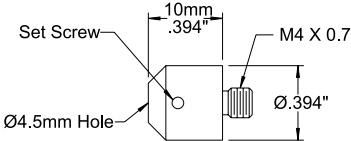
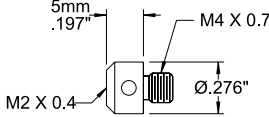
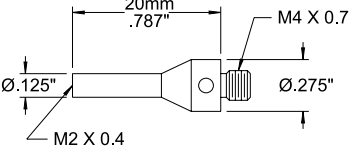
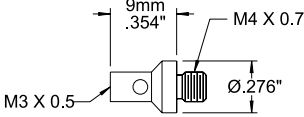
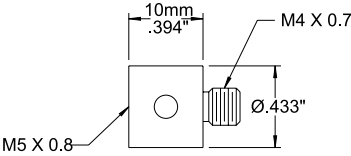
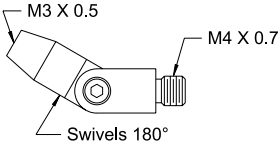
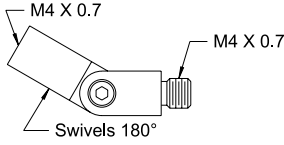
Adapters		Part Number
Actual Size		
 <p>Set Screw 10mm .394" M4 X 0.7 Ø4.5mm Hole Ø.394"</p>	392	
 <p>5mm .197" M2 X 0.4 M4 X 0.7 Ø.276"</p>	399	
 <p>20mm .787" M4 X 0.7 Ø.125" M2 X 0.4 Ø.275"</p>	825-E20	
 <p>9mm .354" M3 X 0.5 M4 X 0.7 Ø.276"</p>	393	
 <p>10mm .394" M4 X 0.7 M5 X 0.8 Ø.433"</p>	854	
<p>Adjustable Stylus Knuckle</p>  <p>M3 X 0.5 M4 X 0.7 Swivels 180°</p>	851	
<p>Adjustable Stylus Knuckle</p>  <p>M4 X 0.7 M4 X 0.7 Swivels 180°</p>	852	

MISCELLANEOUS ADAPTERS

CMM REPLACEMENT STYLUS

Miscellaneous Adapters		Part Number
Actual Size		
		262-AD9
		6001
		6002
		855
		6003
		6006
		6007
		6008
		853
		6009
		6010

Actual Size	Part Number
	389
	397
	390
	CP-1486
	CP-3932

REPLACEMENT STYLI for FARO

Ruby, Carbide and Delrin Ball Styli				
Scale 1:2	A Ball Size	B Stem Dia.	Ball Material	Part Number
			Ruby	CPF-062R
			Carbide	CPF-062
			Delrin	CPF-062D
			Ruby	CPF-125R
			Carbide	CPF-125
			Delrin	CPF-125D
			Ruby	CPF-250R
			Carbide	CPF-250
			Delrin	CPF-250D
			Ruby	N/A
			Carbide	CPF-500
			Delrin	N/A







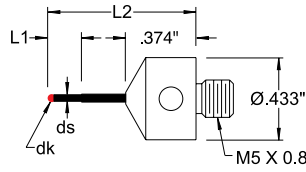

REPLACEMENT STYLI for FARO

Stylus Extensions		
Scale 1:2	A Length	Part Number
	50.8mm 2.000"	CPF-E2000
	76.2mm 3.000"	CPF-E3000
	101.6mm 4.000"	CPF-E4000
	152.4mm 6.000"	CPF-E6000

Adapters		
Scale 1:2	A Tap Size	Part Number
	M2 x 0.4	CPF-AD2
	M2.5 x 0.45	CPF-AD2.5
	4-48 UNF	CPF-AD4-48
	M3 x 0.5	CPF-AD3
	M4 x 0.7	CPF-AD4
	M5 x 0.8	CPF-AD5
1.000" Long	3/8 - 24 UNF	CPF-AD38
1.000" Long	M6 x 1	CPF-AD6

Ruby Ball Styli – Stepped Shafts
Carbide Stems

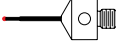

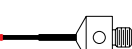
Scale 1:2	dk Ball Size	ds Stem Diameter	L1 EWL	L2 Length	Stem Material	Ball Material	Part Number
	.3mm .012"	.20mm .008"	2.2mm .087"	20.0mm .787"	Tungsten Carbide	Ruby	CPZ000-0320
						Carbide	CPZ000-0320C
	.5mm .020"	.38mm .015"	3.25mm .128"	20.0mm .787"	Tungsten Carbide	Ruby	CPZ000-0520
						Carbide	CPZ000-0520C
	.6mm .024"	.46mm .018"	4.29mm .169"	20.0mm .787"	Tungsten Carbide	Ruby	CPZ000-0620
						Carbide	CPZ000-0620C
	.7mm .028"	.53mm .021"	4.34mm .171"	20.0mm .787"	Tungsten Carbide	Ruby	CPZ000-0720
						Carbide	CPZ000-0720C
	.8mm .032"	.56mm .022"	4.37mm .172"	20.0mm .787"	Tungsten Carbide	Ruby	CPZ000-0820
						Carbide	CPZ000-0820C
	1.0mm .039"	.71mm .028"	4.47mm .176"	20.0mm .787"	Tungsten Carbide	Ruby	CPZ000-1020
						Carbide	CPZ000-1020C
	1.0mm .039"	.71mm .028"	4.50mm .177"	25.0mm .984"	Tungsten Carbide	Ruby	CPZ000-1025
	1.0mm .039"	.71mm .028"	10.5mm .413"	30.0mm 1.181"	Tungsten Carbide	Ruby	CPZ000-1030
	1.5mm .059"	1.0mm .039"	10.5mm .413"	30.0mm 1.181"	Tungsten Carbide	Ruby	CPZ000-1530

CMM REPLACEMENT STYLI

M5 THREADED STYLI

Ruby Ball Styli – Stepped Extended Shafts Carbide Stems

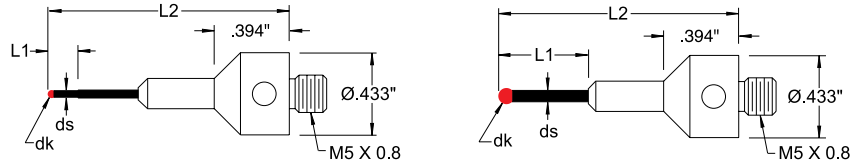

Scale 1:2	dk Ball Size	ds Stem Diameter	L1 EWL	L2 Length	Stem Material	Ball Material	Part Number
	.8mm .032"	.61mm .024"	4.0mm .157"	32.0mm 1.260"	Tungsten Carbide	Ruby	CPZ030-8060
	1.0mm .039"	.79mm .031"	4.5mm .177"	32.0mm 1.260"	Tungsten Carbide	Ruby	CPZ030-8061
	1.35mm .053"	1.0mm .039"	12.0mm .472"	32.0mm 1.260"	Tungsten Carbide	Ruby	CPZ030-8062
	1.35mm .053"	1.0mm .039"	19.0mm .748"	44.0mm 1.732"	Tungsten Carbide	Ruby	CPZ030-8063
	1.5mm .059"	1.0mm .039"	12.0mm .472"	32.0mm 1.260"	Tungsten Carbide	Ruby	CPZ030-0864
	1.5mm .059"	1.0mm .039"	19.0mm .748"	44.0mm 1.732"	Tungsten Carbide	Ruby	CPZ030-8065
	2.0mm .079"	1.5mm .059"	12.0mm .472"	32.0mm 1.260"	Tungsten Carbide	Ruby	CPZ030-8066
	2.0mm .079"	1.5mm .059"	19.0mm .748"	44.0mm 1.732"	Tungsten Carbide	Ruby	CPZ030-8067
	2.0mm .079"	1.5mm .059"	33.0mm 1.299"	58.0mm 2.283"	Tungsten Carbide	Ruby	CPZ030-8068
	2.5mm .098"	1.5mm .059"	12.0mm .472"	32.0mm 1.260"	Tungsten Carbide	Ruby	CPZ030-8069
	2.5mm .098"	1.5mm .059"	19.0mm .748"	44.0mm 1.732"	Tungsten Carbide	Ruby	CPZ030-8070
	2.5mm .098"	1.5mm .059"	33.0mm 1.299"	58.0mm 2.283"	Tungsten Carbide	Ruby	CPZ030-8071

Ruby Ball Styli – Straight Shafts
Carbide Stems

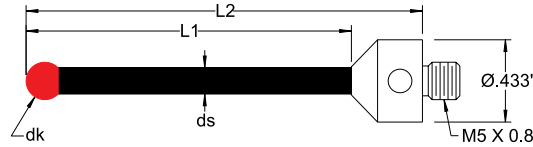

Scale 1:2	dk Ball Size	ds Stem Diameter	L1 EWL	L2 Length	Stem Material	Ball Material	Part Number
	1.35mm .053"	1.0mm .039"	10.5mm .413"	20.0mm .787"	Tungsten Carbide	Ruby	CPZ000-1320
	1.35mm .053"	1.0mm .039"	15.5mm .610"	25.0mm .984"	Tungsten Carbide	Ruby	CPZ000-1325
	1.5mm .059"	1.0mm .039"	10.5mm .413"	20.0mm .787"	Tungsten Carbide	Ruby	CPZ000-1520
	1.5mm .059"	1.0mm .039"	15.5mm .610"	25.0mm .984"	Tungsten Carbide	Ruby	CPZ000-1525
	2.0mm .079"	1.0mm .039"	10.5mm .413"	20.0mm .787"	Tungsten Carbide	Ruby	CPZ000-2020
	2.0mm .079"	1.0mm .039"	15.5mm .610"	25.0mm .984"	Tungsten Carbide	Ruby	CPZ000-2025
	2.0mm .079"	1.5mm .059"	20.5mm .807"	30.0mm 1.181"	Tungsten Carbide	Ruby	CPZ000-2030
	2.0mm .079"	1.5mm .059"	30.5mm 1.201"	40.0mm 1.575"	Tungsten Carbide	Ruby	CPZ000-2040
	2.5mm .098"	1.5mm .059"	10.5mm .413"	20.0mm .787"	Tungsten Carbide	Ruby	CPZ000-2520
	2.5mm .098"	1.5mm .059"	15.5mm .610"	25.0mm .984"	Tungsten Carbide	Ruby	CPZ000-2525
	2.5mm .098"	1.5mm .059"	20.5mm .807"	30.0mm 1.181"	Tungsten Carbide	Ruby	CPZ000-2530
	3.0mm .118"	2.0mm .079"	15.5mm .610"	25.0mm .984"	Tungsten Carbide	Ruby	CPZ030-9010
	3.0mm .118"	2.0mm .079"	24.0mm .945"	33.5mm 1.319"	Tungsten Carbide	Ruby	CPZ342-8020
	3.0mm .118"	2.0mm .079"	40.5mm 1.595"	50.0mm 1.969"	Tungsten Carbide	Ruby	CPZ030-9011
	3.0mm .118"	2.0mm .079"	48.5mm 1.909"	58.0mm 2.283"	Tungsten Carbide	Ruby	CPZ342-8021

CMM REPLACEMENT STYLI





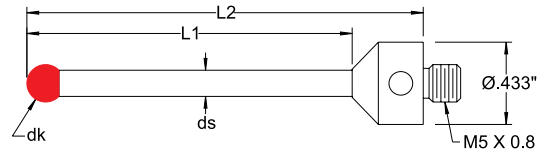



M5 THREADED STYLI

Ruby Ball Styli – Straight Shafts



Scale 1:2	dk Ball Size	ds Stem Diameter	L1 EWL	L2 Length	Stem Material	Ball Material	Part Number
	4.0mm .157"	2.0mm .079"	24.0mm .945"	33.5mm 1.319"	Tungsten Carbide	Ruby	CPZ342-8025
	4.0mm .157"	2.0mm .079"	54.5mm 2.146"	64.0mm 2.520"	Tungsten Carbide	Ruby	CPZ030-9012
	5.0mm .197"	3.5mm .138"	40.0mm 1.575"	50.0mm 1.969"	Stainless Steel	Ruby	CPZ030-9013
	5.0mm .197"	3.5mm .138"	43.5mm 1.713"	53.0mm 2.087"	Tungsten Carbide	Ruby	CPZ342-8022
	5.0mm .197"	3.5mm .138"	65.0mm 2.558"	75.0mm 2.953"	Stainless Steel	Ruby	CPZ030-9015
	6.0mm .236"	4.0mm .157"	39.0mm 1.535"	50.0mm 1.969"	Carbon Fiber	Ruby	9550-6R
	6.0mm .236"	3.5mm .138"	44.5mm 1.752"	54.0mm 2.126"	Tungsten Carbide	Ruby	CPZ342-8026
	6.0mm .236"	4.0mm .157"	64.0mm 2.519"	75.0mm 2.953"	Carbon Fiber	Ruby	9575-6R
	6.0mm .236"	4.0mm .157"	89.0mm 3.504"	100.0mm 3.937"	Carbon Fiber	Ruby	95100-6R
	7.0mm .276"	3.5mm .138"	45.5mm 1.791"	55.0mm 2.165"	Tungsten Carbide	Ruby	CPZ342-8027
	8.0mm .315"	6.35mm .250"	37.0mm 1.456"	50.0mm 1.969"	Carbon Fiber	Ruby	9550-8R
	8.0mm .315"	6.0mm .236"	56.0mm 2.205"	63.5mm 2.500"	Stainless Steel	Ruby	CPZ342-8023
	8.0mm .315"	6.0mm .236"	61.0mm 2.401"	74.0mm 2.913"	Stainless Steel	Ruby	CPZ030-9014
	8.0mm .315"	6.0mm .236"	62.0mm 2.441"	75.0mm 2.953"	Stainless Steel	Ruby	CPZ030-9016
	8.0mm .315"	6.35mm .250"	62.0mm 2.440"	75.0mm 2.953"	Carbon Fiber	Ruby	9575-8R
	8.0mm .315"	6.0mm .236"	87.0mm 3.425"	100.0mm 3.937"	Stainless Steel	Ruby	CPZ030-9017
	8.0mm .315"	6.35mm .250"	87.0mm 3.425"	100.0mm 3.937"	Carbon Fiber	Ruby	95100-8R
	8.0mm .315"	6.0mm .236"	107.0mm 4.213"	114.5mm 4.508"	Stainless Steel	Ruby	CPZ342-8024
	9.0mm .354"	6.0mm .236"	57.0mm 2.244"	64.5mm 2.539"	Stainless Steel	Ruby	CPZ342-8028
	10.0mm .394"	6.35mm .250"	37.0mm 1.456"	50.0mm 1.969"	Carbon Fiber	Ruby	9550-10R
	10.0mm .394"	6.0mm .236"	58.0mm 2.283"	65.5mm 2.579"	Stainless Steel	Ruby	CPZ342-8029
	10.0mm .394"	6.35mm .250"	62.0mm 2.440"	75.0mm 2.953"	Carbon Fiber	Ruby	9575-10R
	10.0mm .394"	6.0mm .236"	105.0mm 4.134"	118.0mm 4.646"	Stainless Steel	Ruby	CPZ030-9018

M5 THREADED STYLI

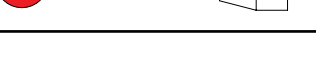
Actual Size	dk Ball Size	ds Stem Diameter	L1 EWL	L2 Length	Stem Material	Ball Material	Part Number
	6.0mm .236"	4.0mm .157"	139.0mm 5.472"	150.0mm 5.905"	Carbon Fiber	Ruby	95150-6R
	6.0mm .236"	4.0mm .157"	189.0mm 7.441"	200.0mm 7.874"	Carbon Fiber	Ruby	95200-6R
	6.0mm .236"	4.0mm .157"	289.0mm 11.378"	300.0mm 11.811"	Carbon Fiber	Ruby	95300-6R
	8.0mm .315"	6.35mm .250"	137.0mm 5.394"	150.0mm 5.905"	Carbon Fiber	Ruby	95150-8R
	8.0mm .315"	6.35mm .250"	187.0mm 7.362"	200.0mm 7.874"	Carbon Fiber	Ruby	95200-8R
	8.0mm .315"	6.35mm .250"	287.0mm 11.299"	300.0mm 11.811"	Carbon Fiber	Ruby	95300-8R
	10.0mm .394"	6.35mm .250"	87.0mm 3.425"	100.0mm 3.937"	Carbon Fiber	Ruby	95100-10R
	10.0mm .394"	6.35mm .250"	137.0mm 5.394"	150.0mm 5.905"	Carbon Fiber	Ruby	95150-10R
	10.0mm .394"	6.35mm .250"	187.0mm 7.362"	200.0mm 7.874"	Carbon Fiber	Ruby	95200-10R
	10.0mm .394"	6.35mm .250"	287.0mm 11.299"	300.0mm 11.811"	Carbon Fiber	Ruby	95300-10R

CMM REPLACEMENT STYLI

M5 THREADED STYLI

Ruby Ball Styli – Straight Shafts Ceramic Stems

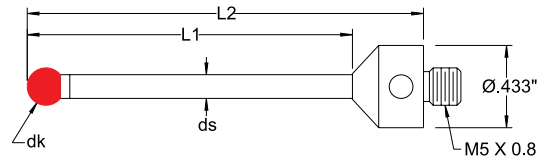

Scale 1:2	dk Ball Size	ds Stem Diameter	L1 EWL	L2 Length	Stem Material	Part Number
	5.0mm .197"	3.18mm .125"	43.5mm 1.713"	53.0mm 2.087"	Ceramic	CPZ342-8013
	6.0mm .236"	3.18mm .125"	44.5mm 1.752"	54.0mm 2.126"	Ceramic	CPZ342-8016
	7.0mm .276"	3.18mm .125"	45.5mm 1.791"	55.0mm 2.165"	Ceramic	CPZ342-8017
	8.0mm .315"	4.75mm .187"	56.0mm 2.205"	63.5mm 2.500"	Ceramic	CPZ342-8014
	8.0mm .315"	4.75mm .187"	107.0mm 4.213"	114.5mm 4.508"	Ceramic	CPZ342-8015
	9.0mm .354"	4.75mm .187"	57.0mm 2.244"	64.5mm 2.539"	Ceramic	CPZ342-8018
	10.0mm .394"	4.75mm .187"	58.0mm 2.283"	65.5mm 2.579"	Ceramic	CPZ342-8019

Ruby Ball Styli – Standard Probes Straight Shafts Steel Stems

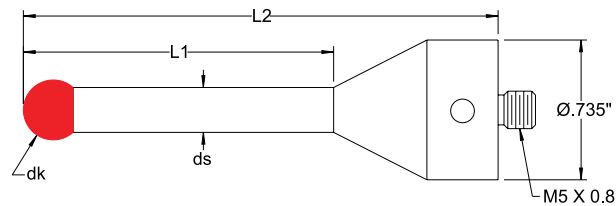

Scale 1:2	dk Ball Size	ds Stem Diameter	L1 EWL	L2 Length	Stem Material	Part Number
	8.0mm .315"	6.0mm .236"	41.5mm 1.634"	63.5mm 2.500"	Stainless Steel	CPZ342-8123
	8.0mm .315"	6.0mm .236"	92.5mm 3.642"	114.5mm 4.508"	Stainless Steel	CPZ342-8124
	9.0mm .354"	6.0mm .236"	42.5mm 1.673"	64.5mm 2.539"	Stainless Steel	CPZ342-8128
	10.0mm .394"	6.0mm .236"	43.5mm 1.713"	65.5mm 2.579"	Stainless Steel	CPZ342-8129

Ruby Ball Styli – Standard Probes
Straight Shafts
Ceramic Shaft

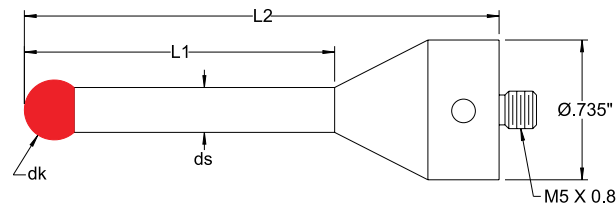

Scale 1:2	dk Ball Size	ds Stem Diameter	L1 EWL	L2 Length	Stem Material	Part Number
	8.0mm .315"	4.75mm .187"	41.5mm 1.634"	63.5mm 2.500"	Ceramic	CPZ342-8114
	8.0mm .315"	4.75mm .187"	92.5mm 3.642"	114.5mm 4.508"	Ceramic	CPZ342-8115
	9.0mm .354"	4.75mm .187"	42.5mm 1.673"	64.5mm 2.539"	Ceramic	CPZ342-8118
	10.0mm .394"	4.75mm .187"	43.5mm 1.713"	65.5mm 2.579"	Ceramic	CPZ342-8119

Ruby Ball Styli – Universal Probes
Straight Shafts
Carbide or Steel Stems
For Use With Analog
3D Probe Heads

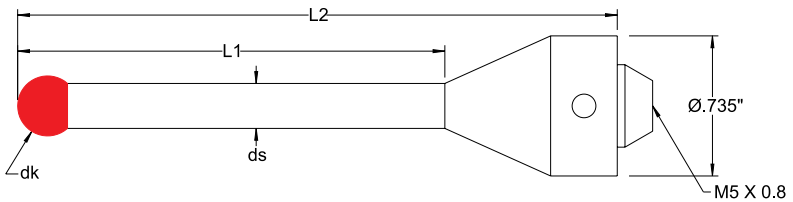

Scale 1:2	dk Ball Size	ds Stem Diameter	L1 EWL	L2 Length	Stem Material	Part Number
	3.0mm .118"	2.0mm .079"	21.5mm .846"	50.0mm 1.968"	Tungsten Carbide	CPZ331-9096
	3.0mm .118"	2.0mm .079"	18.0mm .709"	115.0mm 4.528"	Tungsten Carbide	CPZ331-9098
	8.0mm .315"	6.0mm .236"	57.0mm 2.244"	80.0mm 3.150"	Stainless Steel	CPZ331-9097
	8.0mm .315"	6.0mm .236"	56.5mm 2.224"	115.0mm 4.528"	Stainless Steel	CPZ331-9099

CMM REPLACEMENT STYLI

M5 THREADED STYLI

Ruby Ball Styli – Light Weight Titanium Probes

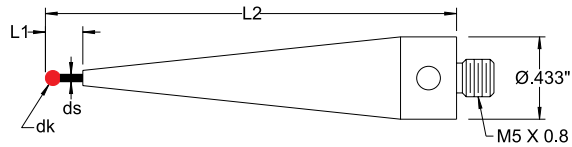

Scale 1:2	dk Ball Size	ds Stem Diameter	L1 EWL	L2 Length	Stem Material	Ball Material	Part Number
	0.3mm .012"	0.20mm .008"	2.16mm .085"	55.0mm 2.165"	Tungsten Carbide	Ruby Carbide	CPZ000-0066 CPZ000-0066C
	0.5mm .020"	0.38mm .015"	3.25mm .128"	55.0mm 2.165"	Tungsten Carbide	Ruby Carbide	CPZ000-0067 CPZ000-0067C
	0.6mm .024"	0.46mm .018"	4.29mm .169"	55.0mm 2.165"	Tungsten Carbide	Ruby Carbide	CPZ000-0068 CPZ000-0068C
	0.7mm .028"	0.53mm .021"	4.34mm .171"	55.0mm 2.165"	Tungsten Carbide	Ruby Carbide	CPZ000-0069 CPZ000-0069C
	0.8mm .032"	0.56mm .022"	4.37mm .172"	55.0mm 2.165"	Tungsten Carbide	Ruby Carbide	CPZ000-0070 CPZ000-0070C
	1.0mm .039"	0.8mm .032"	4.0mm .157"	55.0mm 2.165"	Tungsten Carbide	Ruby	CPZ000-0071
	1.5mm .059"	1.0mm .039"	5.0mm .197"	55.0mm 2.165"	Tungsten Carbide	Ruby	CPZ000-0072
	2.0mm .079"	1.0mm .039"	5.0mm .197"	55.0mm 2.165"	Tungsten Carbide	Ruby	CPZ000-0073
	2.5mm .098"	1.5mm .059"	5.0mm .197"	55.0mm 2.165"	Tungsten Carbide	Ruby	CPZ000-0274
	3.5mm .138"	1.5mm .059"	10.0mm .394"	55.0mm 2.165"	Tungsten Carbide	Ruby	CPZ000-0375

Ruby Ball Styli –
Mini Probes

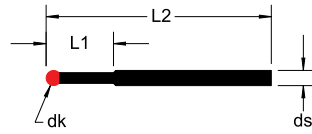

Scale 2:1	dk Ball Size	ds Stem Diameter	L1 EWL	L2 Length	Ball Material	Part Number
	0.3mm .012"	1.0mm .039"	2.16mm .085"	15.0mm .591"	Ruby	CPZ341-8450
					Carbide	CPZ341-8450C
	0.5mm .020"	1.0mm .039"	3.25mm .128"	15.0mm .591"	Ruby	CPZ341-8451
					Carbide	CPZ341-8451C
	0.6mm .024"	1.0mm .039"	4.29mm .169"	15.0mm .591"	Ruby	CPZ341-8452
					Carbide	CPZ341-8452C
	0.7mm .028"	1.0mm .039"	4.34mm .171"	15.0mm .591"	Ruby	CPZ341-8455
					Carbide	CPZ341-8455C
	0.8mm .031"	1.0mm .039"	4.37mm .172"	15.0mm .591"	Ruby	CPZ341-8453
					Carbide	CPZ341-8453C
	1.0mm .039"	1.0mm .039"	4.50mm .177"	15.0mm .591"	Ruby	CPZ341-8454
					Carbide	CPZ341-8454C
	1.0mm .039"	1.0mm .039"	4.50mm .177"	25.0mm .984"	Ruby	CPZ341-8504
					Carbide	CPZ341-8504C
	1.35mm .053"	1.0mm .039"	25.0mm .984"	25.0mm .984"	Ruby	CPZ341-8500
					Carbide	CPZ341-8500C
	1.5mm .059"	1.0mm .039"	25.0mm .984"	25.0mm .984"	Ruby	CPZ341-8501
					Carbide	CPZ341-8501C
	2.0mm .079"	1.5mm .059"	25.0mm .984"	25.0mm .984"	Ruby	CPZ341-8502
					Carbide	CPZ341-8502C
	2.5mm .098"	1.5mm .059"	25.0mm .984"	25.0mm .984"	Ruby	CPZ341-8503
					Carbide	CPZ341-8503C

Mini Probes are for use with the Mini Probe Holders on page 68. They are held in with set screws supplied with the Mini Probe Holders.



M5 THREADED STYLI

Mini Probe Holders		
Actual Size		Part Number
Single – 1 Way Stylus Holder		CPZ000-8365
Single – 1 Way Stylus Holder		CPZ000-8366
5 Way Star Stylus Holder		CPZ341-8367
5 Way Star Stylus Holder		CPZ341-8368

Mini Probes Holders are for use with the Mini Probe on page 67. They are held in with set screws supplied with the Mini Probe Holders.

Carbide Ball Styli

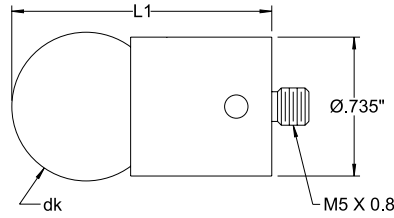

Scale 1:2	dk Ball Size	L1 Length	Base Material	Part Number
	15.0mm .591"	35.0mm 1.378"	Stainless Steel	CPZ000-0019
	20.0mm .787"	35.0mm 1.378"	Stainless Steel	CPZ000-0018
	25.0mm .984"	35.0mm 1.378"	Stainless Steel	CPZ000-0017

Star Cube

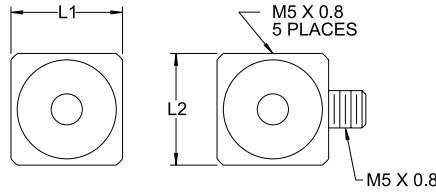

Scale 1:2	L1	L2	Part Number
	15.0mm .591"	15.0mm .591"	CPZ341-8361
	20.0mm .787"	20.0mm .787"	CPZ342-8002

M5 THREADED STYLI

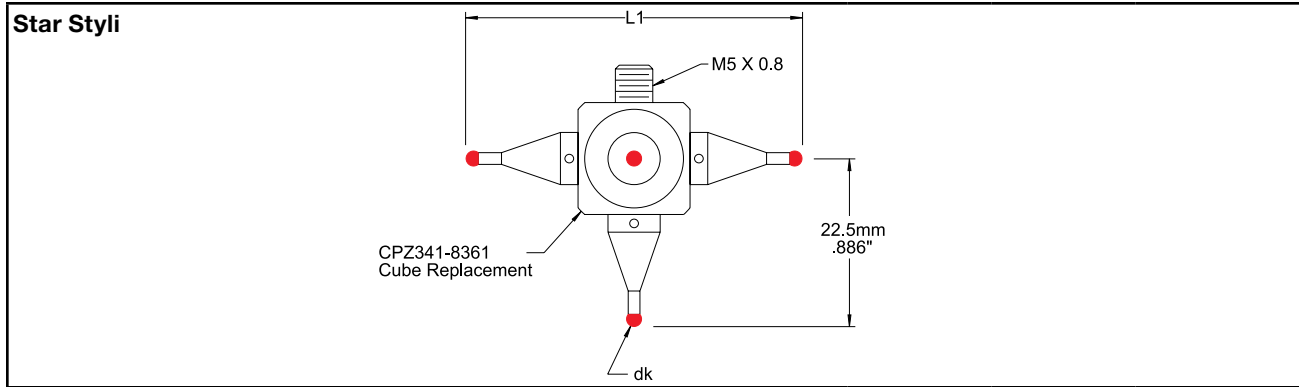

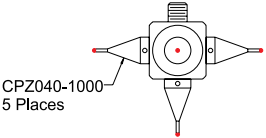
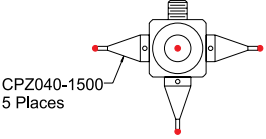
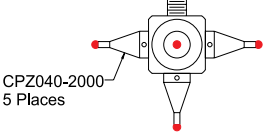
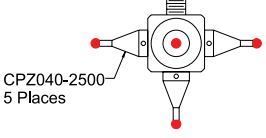
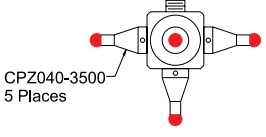
Scale 1:2	dk Ball Size	L1 Span	Part Number
 <p>CPZ040-1000 5 Places</p>	1.0mm .039"	45.0mm 1.772"	CPZ000-0020
 <p>CPZ040-1500 5 Places</p>	1.5mm .059"	45.0mm 1.772"	CPZ000-0030
 <p>CPZ040-2000 5 Places</p>	2.0mm .079"	45.0mm 1.772"	CPZ000-0040
 <p>CPZ040-2500 5 Places</p>	2.5mm .098"	45.0mm 1.772"	CPZ000-0050
 <p>CPZ040-3500 5 Places</p>	3.5mm .138"	45.0mm 1.772"	CPZ000-0060

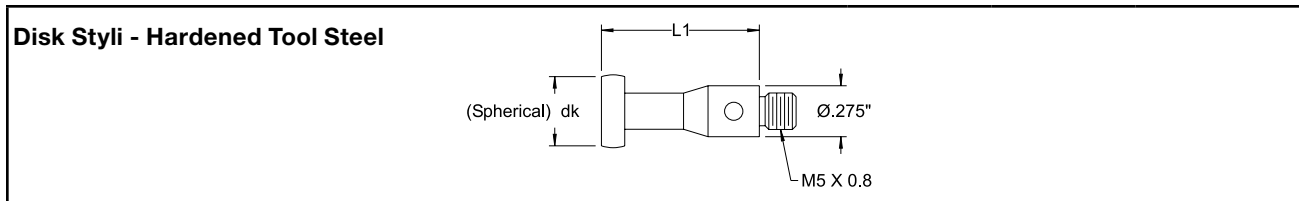

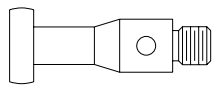
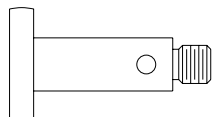
Actual Size	dk Diameter	L1 Length	Part Number
	10.0mm .394"	21.5mm .846"	CPZ341-8090
	15.0mm .591"	21.5mm .846"	CPZ341-8095

Disk Styli - Hardened Tool Steel continued on page 71

Disk Styli – Hardened Tool Steel

continued from page 70

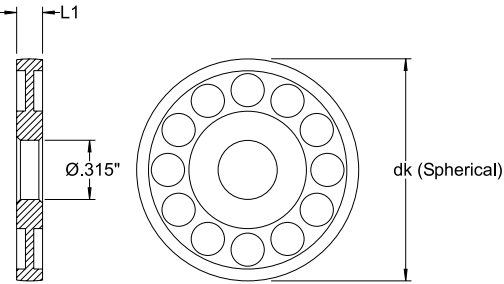

Scale 1:2	dk Diameter	L1 Thickness	Part Number
	30.0mm 1.181"	3.5mm .138"	CPZ341-0203
	40.0mm 1.575"	5.0mm .196"	CPZ341-0204
	50.0mm 1.969"	7.0mm .276"	CPZ341-0205
	60.0mm 2.362"	8.0mm .315"	CPZ341-0206





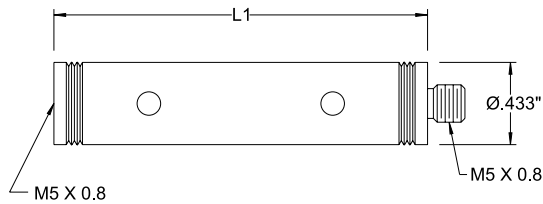

Mount to Extensions or Holders with Screws on page 74.

M5 THREADED STYLI

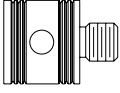
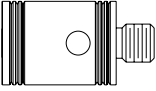
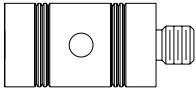
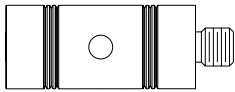
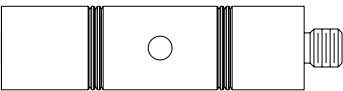
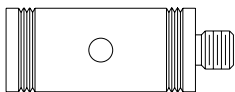
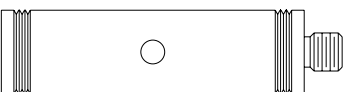
CMM REPLACEMENT STYLI

Stylus Extensions





Actual Size	L1 Length	Material	Part Number
	10.0mm .394"	Stainless Steel	CPZ341-0250
	15.0mm .591"	Stainless Steel	CPZ341-0251
	20.0mm .787"	Stainless Steel	CPZ341-0252
	25.0mm .984"	Stainless Steel	CPZ341-0253
	40.0mm 1.575"	Stainless Steel	CPZ341-0254
	25.0mm .984"	Aluminum	CPZ000-0012
	40.0mm 1.575"	Aluminum	CPZ341-8261
	50.0mm 1.969"	Aluminum	CPZ000-0011
	60.0mm 2.362"	Aluminum	CPZ341-8262
	80.0mm 3.150"	Aluminum	CPZ341-8263
	100.0mm 3.937"	Aluminum	CPZ341-8264
	120.0mm 4.724"	Aluminum	CPZ341-8265

Stylus Extensions continued on page 73

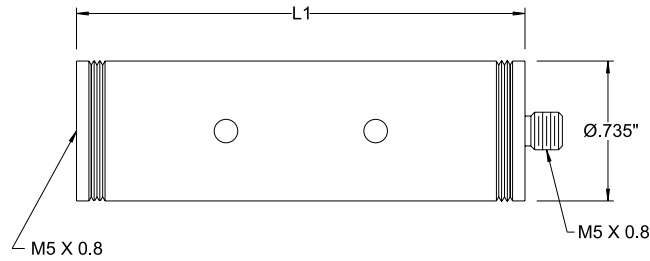
Stylus Extensions
continued from page 72

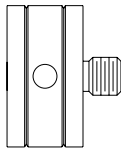
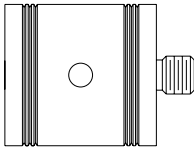
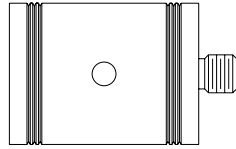
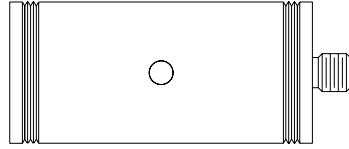
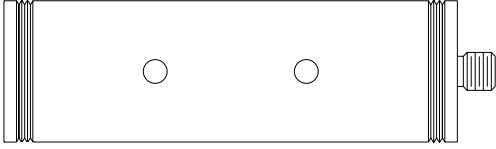

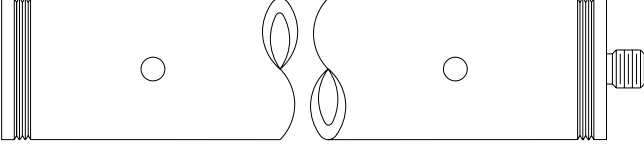
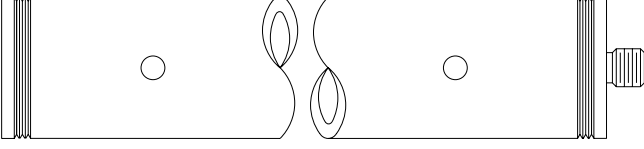
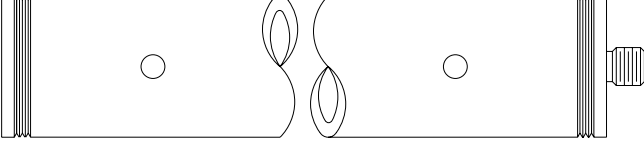
Actual Size	L1 Length	Material	Part Number
	10.0mm .394"	Stainless Steel	CPZ341-0249
	20.0mm .787"	Stainless Steel	CPZ341-0248
	25.0mm .984"	Stainless Steel	CPZ341-0247
	40.0mm 1.575"	Aluminum	CPZ341-8425
	60.0mm 2.362"	Aluminum	CPZ341-8424
	80.0mm 3.150"	Aluminum	CPZ341-8423
	100.0mm 3.937"	Aluminum	CPZ341-8422
	150.0mm 5.906"	Aluminum	CPZ341-8421
	200.0mm 7.874"	Aluminum	CPZ341-8420

M5 THREADED STYLI

Adapter Screws

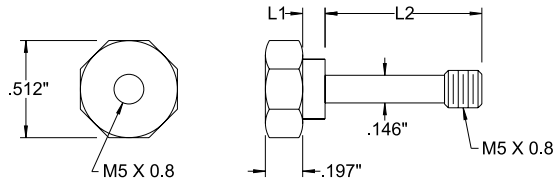

Actual Size	L1	L2	Part Number
	1.3mm .051"	7.5mm .295"	CPZ341-0213
	1.3mm .051"	10.0mm .394"	CPZ341-0212
	3.0mm 0.118"	10.0mm .394"	CPZ341-0214
	3.0mm 0.118"	21.0mm .827"	CPZ341-0211
	3.0mm 0.118"	26.0mm 1.024"	CPZ341-0210

Adapter Screws

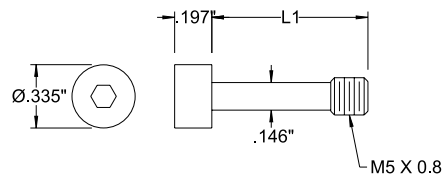

Actual Size	L1	Part Number
	21.0mm .827"	CPZ341-0221
	26.0mm 1.024"	CPZ341-0220

Adjustable Rotary Adapter

Actual Size	Part Number
	CPZ341-8356

Adjustable Stylus Knuckle	
Actual Size	Part Number
<p>36mm 1.417"</p> <p>Ø.433"</p> <p>M5 X 0.8</p>	CPZ000-0010
<p>36mm 1.417"</p> <p>Ø.735"</p> <p>M5 X 0.8</p>	CPZ342-9003

Adjustable Rotary Adapter	
Actual Size	Part Number
<p>30mm 1.181"</p> <p>Ø.735" 2 Places</p> <p>Ø.975"</p> <p>M5 X 0.8 Both Ends</p>	CPZ000-0015

Universal Rotary Adapter	
Actual Size	Part Number
<p>For Use With Analog 3D Probe Heads</p> <p>32mm 1.260"</p> <p>Ø.735"</p> <p>Ø.875"</p> <p>M5 X 0.8</p>	CPZ331-9094

ADAPTERS

CMM REPLACEMENT STYLUS

Special Adapter - For Use With Analog 3D Probe Heads	
Actual Size	Part Number
	CPZ331-0001

Special Probe Holders - For Use With Analog 3D Probe Heads	
Actual Size	Part Number
	CPZ341-8350
	CPZ341-8351
	CPZ341-8352

Hand Held Spherical Ball-Tipped Scribers for Surface Defect Analysis

Surface Defect Scriber – Straight	A Ball Diameter	Part Number
	.010"	SDS-0100
	.015"	SDS-0150
	.020"	SDS-0200
	.030"	SDS-0300
	1.0mm	SDS-1.0mm
	.040"	SDS-0400
	1.5mm	SDS-1.5mm
	.060"	SDS-0600
	2.0mm	SDS-2.0mm
	.080"	SDS-0800
	.120"	SDS-1200
	.160"	SDS-1600
	.240"	SDS-2400

TUNGSTEN CARBIDE BALL
AFBMA GRADE 25
DIA. TOLERANCE ± .0001"
SPHERICITY .000025"

1.60" 5.00" 0.375"

STAINLESS STEEL STEM

ALUMINUM HANDLE WITH KNURLED GRIP

Hand Held Spherical Ball-Tipped Scribers for Surface Defect Analysis

Surface Defect Scriber – Right Angle	A Ball Diameter	Part Number
	.010"	SDSRA-0100
	.015"	SDSRA-0150
	.020"	SDSRA-0200
	.030"	SDSRA-0300
	1.0mm	SDSRA-1.0mm
	.040"	SDSRA-0400
	1.5mm	SDSRA-1.5mm
	.060"	SDSRA-0600
	2.0mm	SDSRA-2.0mm
	.080"	SDSRA-0800

TUNGSTEN CARBIDE BALL
AFBMA GRADE 25
DIA. TOLERANCE ± .0001"
SPHERICITY .000025"

1.60" 5.00" 0.375"

.500"

STAINLESS STEEL STEM

ALUMINUM HANDLE WITH KNURLED GRIP

Contour Styli for Form Measurement	
Replacement Stylus Tip for Mitutoyo Contour Measurement	Part Number
	CPM354884
	Replacement for Mitutoyo Part Number: 354884 or SPH-71

Contour Styli for Form Measurement	
Replacement Stylus Tip for Mahr (MarSurf) Contour Measurement	Part Number
	CPM6850286
	Replacement for Mahr Part Number: 6850286
	CPM6851517
	Replacement for Mahr Part Number: 6851517

Contour Styli for Form Measurement	
Special order or Refurbished Stylus Tips	
<p>A variety of other contour replacement stylus tips are available through special order. We can also refurbish your damaged stylus tips (except those listed as standard catalog items). Upon request, replacement stylus tips can be manufactured from hardened high speed steel. Damaged surface roughness testing styli and/or worn diamond tips can also be repaired.</p>	

Height Gauge Ball Tip Offset Probes (for Brown & Sharpe Micro-Hite)

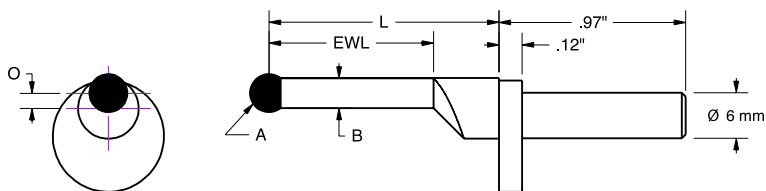

A Ball Diameter	B Stem Diameter	L Length	EWL	O Offset	Ball Material	Part Number
3.0mm	.078"	1.203"	.461"	.155"	Carbide	MH-223C
					Ruby	MH-223R
5.0mm	.156"	1.195"	.855"	.116"	Carbide	MH-224C
					Ruby	MH-224R

Diamond Tipped Contact (Spherical Point)

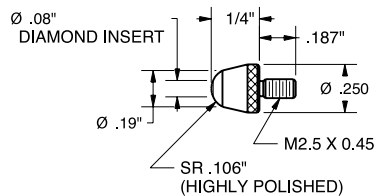

Part Number

172246-01

For 4-48
Threaded
Indicators use
our adaptor
Part Number
343-E375 (page
31 of catalog)

Custom Ball Gauges Made To Your Specifications – Available In Single Or Double End

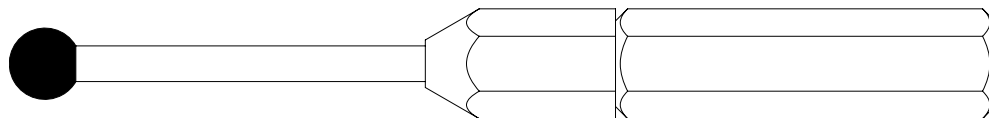

Ruby Balls

Synthetic Ruby (Sapphire)
AFBMA Grade 10
Basic Diameter Tolerance $\pm .0001$ "
Sphericity .00001"



Ruby Ball
without Hole



Ruby Ball
with Blind Hole

Available with or without Hole

Ball Diameter	Hole Diameter x Depth	Part Number
1/32"	No Hole	RB.0312
1/32"	.013" x .015"	RB.0312H
1.0mm	No Hole	RB1.0MM
1.0mm	.015" x .020"	RB1.0MMH
3/64"	No Hole	RB.0469
3/64"	.018" x .025"	RB.0469H
1.35mm	No Hole	RB1.35MM
1.35mm	.018" x .025"	RB1.35MMH
1.5mm	No Hole	RB1.5MM
1.5mm	.018" x .030"	RB1.5MMH
1/16"	No Hole	RB.0625
1/16"	.018" x .030"	RB.0625H
2.0mm	No Hole	RB2.0MM
2.0mm	.025" x .040"	RB2.0MMH
3/32"	No Hole	RB.0937
3/32"	.025" x .045"	RB.0937H
2.5mm	No Hole	RB2.5MM
2.5mm	.025" x .045"	RB2.5MMH
3.0mm	No Hole	RB3.0MM
3.0mm	.031" x .059"	RB3.0MMH
1/8"	No Hole	RB.1250
1/8"	.031" x .059"	RB.1250H
3.5mm	No Hole	RB3.5MM
3.5mm	.031" x .059"	RB3.5MMH
5/32"	No Hole	RB.1562
5/32"	.059" x .080"	RB.1562H

Ball Diameter	Hole Diameter x Depth	Part Number
4.0mm	No Hole	RB4.0MM
4.0mm	.059" x .080"	RB4.0MMH
.1875"	No Hole	RB.1875
.1875"	.059" x .080"	RB.1875H
5.0mm	No Hole	RB5.0MM
5.0mm	.059" x .080"	RB5.0MMH
7/32"	No Hole	RB.2187
7/32"	.059" x .100"	RB.2187H
6.0mm	No Hole	RB6.0MM
6.0mm	.059" x .120"	RB6.0MMH
1/4"	No Hole	RB.2500
1/4"	.059" x .120"	RB.2500H
7.0mm	No Hole	RB7.0MM
7.0mm	.059" x .120"	RB7.0MMH
9/32"	No Hole	RB.2812
9/32"	.078" x .140"	RB.2812H
5/16"	No Hole	RB.3125
5/16"	.078" x .156"	RB.3125H
8.0mm	No Hole	RB8.0MM
8.0mm	.078" x .156"	RB8.0MMH
9.0mm	No Hole	RB9.0MM
9.0mm	.078" x .156"	RB9.0MMH
3/8"	No Hole	RB.3750
3/8"	.098" x .187"	RB.3750H
10.0mm	No Hole	RB10.0MM
10.0mm	.098" x .187"	RB10.0MMH

Carbide Probes, Inc.

1328 Research Park Drive
Dayton, Ohio 45432

PHONE: 937.429.9123

FAX: 937.429.2103

TOLL FREE: 1.800.347.4980

www.CarbideProbes.com